



# Roofing System

## Submittal Package

**Project Name:**

**Project Address:**

**Roofing Contractor:**



# Product Data Sheet

## MULE-HIDE STANDARD REINFORCED AND FR REINFORCED EPDM MEMBRANE

### PRODUCT DESCRIPTION

Mule-Hide Standard Reinforced EPDM is a high performance, polyester reinforced membrane that stands up to tearing, impacts, punctures and normal roof traffic. The elastomeric properties of the EPDM membrane compensate for thermal shock and building movement. EPDM membranes provide excellent resistance to ozone and aging. The membrane is manufactured in accordance with the guidelines established by the RMA (Rubber Manufacturers Association) and meets or exceeds the ASTM Standard Specification D 4637, Type II. Also available as a Fire retardant (FR) membrane that is specially formulated to inhibit spread of flame and meet or exceed code body testing criteria for fire retardant roofing membranes.



Mule-Hide STANDARD REINFORCED and FR REINFORCED EPDM membranes are available with in-seam tape that is pre-applied to the sheet. See below for sizes available.

### BASIC USES

The Standard Reinforced and FR Reinforced EPDM membrane is used in mechanically attached and fully adhered roofing systems in new construction, reroofing and recover (retrofit) applications. It may also be used as flexible membrane flashings for walls, curbs, etc, when installing an EPDM membrane roofing systems. The system must be installed over acceptable roof insulation or other suitable substrate. See the Mule-Hide EPDM Specifications Manual for complete specifications and details.

### SPECIFICATIONS

Physical Properties*	Test Method	SPEC. (Pass)	Typical Standard
Tolerance on Nominal Thickness, %	ASTM D 751	± 10	± 10
Thickness Over Scrim, min, in.(mm) .045 .060 .075	ASTM D 4637 Annex	0.015 (0.381)	0.016 (0.406) 0.020 (0.508) 0.032 (0.810)
Weight, lbm/ft <sup>2</sup> (kg/m <sup>2</sup> ) .045 .060 .075			0.27 (1.3) 0.39 (1.9) 0.48 (2.3)
Elongation, Ultimate, min, % .045 & .060 .075	ASTM D 412 Die C	250**	480*** 500***
Tear Strength min, lbf (N) .045, .060 & .075	ASTM D 751 B Tongue Tear	10 (45)	70 (311)
Breaking Strength, min, lbf(N) .045, .060 .075	ASTM D 751 (Grab Method)	90(400)	140(623) 177 (787)
Factory Seam Strength, min.	ASTM D 816 (Modified)	Membrane Rupture	Membrane Rupture
Brittleness point, max, deg.F (deg.C)*	ASTM D 2137	-49(-45)	-49(-45)
Resistance to Heat Aging* Properties after 4 weeks @ 240°F(116°C) Breaking Strength, min, lbf(N) Elongation, Ultimate, min, % Linear Dimensional Change, max, %	ASTM D 573  ASTM D 751 ASTM D 412 Die C ASTM D 1204	80(355) 200** ± 1.0	182 (823) 250** -1.0

# Product Data Sheet

MULE-HIDE STANDARD REINFORCED AND FR REINFORCED EPDM MEMBRANE

## **SPECIFICATIONS - Continued**

Ozone Resistance** Conditions after exposure 100 pphm Ozone in air for 168 hrs @ 104oF(40oC) Specimen wrapped around 3 inch mandrel	ASTM D 1149	No Cracks	No Cracks
Resistance to Water Absorption* After 7 days immersion @ 158oF (70oC), Change in mass, max, %	ASTM D 471	+8, -2**	5.5**
Resistance to Outdoor (Ultraviolet) Weathering - Xenon-Arc, exposure, 0.70 W/m <sup>2</sup> irradiance, 176°F (80°C) black panel temperature	ASTM G 155	No Cracks No Cracking 7,560 kJ/m <sup>2</sup> 3,000 hours	No Cracks No Cracking 33,320 kJ/m <sup>2</sup> 14,000 hours
At 0.35 W/m <sup>2</sup> irradiance, 176°F (80°C) black panel temperature		6,000 hours	28,000 hours
Fungi Resistance	ASTM G21	N/A	0 (no growth)
*Typical properties and characteristics are based on samples tested and are not guaranteed for all samples of this product. This data and information is intended as a guide and does not reflect the specification range for any particular property of this product.			
*Not a Quality Control Test due to the time required for the test or the complexity of the test. However, all tests run on a statistical basis to ensure overall long-term performance of the sheeting.			
***Specimens to be prepared from coating rubber compound, vulcanized in a similar method to the reinforced product.			

<b>LEED Information</b>	
Pre-consumer Recycled Content	5%
Post-consumer Recycled Content	0%
Manufacturing Location	Carlisle, PA or Greenville, IL
Solar Reflectance Index (SRI)	9

## **PACKAGING**

Mule-Hide Standard Reinforced and FR Reinforced EPDM Membranes (with and with-out tape) are available in a variety of sizes with widths up to 10' and lengths up to 100' long. Contact Mule-Hide Products for available roll sizes.

## **BENEFITS & SUPPLEMENTAL STATEMENTS**

- Can be installed over a variety of roof decks
- Outstanding weatherability
- Sheets can be pre-taped for labor savings and consistent seam placement
- Requires no special equipment to install
- Available as a lightweight system
- Full line of pre-taped accessories available

## **CODE APPROVALS/COMPLIANCE**

A variety of Factory Mutual Ratings and Underwriter Laboratory Classifications are available. Contact Mule-Hide Technical Department for additional information. Meets or exceeds ASTM D4637, Type II for reinforced EPDM single-ply membranes.

## **INSTALLATION INSTRUCTIONS**

- 1) Approved insulation shall be attached to the roof deck with an approved insulation adhesive or approved fasteners and plates. Install insulation with its largest dimension perpendicular to the direction of the membrane seams where possible.

# Product Data Sheet

MULE-HIDE STANDARD REINFORCED AND FR REINFORCED EPDM MEMBRANE

---

## **INSTALLATION INSTRUCTIONS - Continued**

- 2) Mechanically Attached Roofing System
  - a) Perimeter sheets to be installed in an approved pattern along all exterior roof edges.
  - b) Mechanical fasteners and plates are installed in the seams of both the perimeter sheets and field sheets and into the roof deck. Use approved fasteners and maintain proper penetration for specific roof deck.
- 3) Fully Adhered Roofing System
  - a) Perimeter sheets are not required.
  - b) The membrane is required to be mechanically attached at the base of all vertical surfaces, roof edges, and angle changes.
  - c) The field of the roof is fully adhered to the substrate with Mule-Hide membrane adhesive.
- 4) All seams are made with Mule-Hide Tape Primer and In-Seam Tape.
- 5) All details will be done in accordance with Mule-Hide details.
- 6) On projects where a Mule-Hide Standard or Premium Warranty is requested, an authorized Mule-Hide representative shall inspect all completed work. This is only a brief summary and not the complete specification. Mule-Hide Specifications, Details, Technical Bulletins, and associated documents should be thoroughly reviewed prior to starting any project. Contact Mule-Hide Products for additional information.

## **PRECAUTIONS**

- Use proper stacking procedures to ensure sufficient stability of the materials.
- Surfaces may be slippery when wet, or due to frost and ice build-up. Exercise caution to prevent falls.
- Exercise care when working near edge of roof.
- Store Mule-Hide membrane in original wrappings in a cool, shaded area. Cover with light colored, breathable, waterproof tarpaulins.
- Pre-Taped membranes should not be exposed to prolonged jobsite storage temperatures in excess of 90°F (32°C), otherwise the shelf life of the Pre-Tape may be affected.
- When using pre-taped membranes in warm, sunny weather, shade the tape end of the rolls until ready to use.

## **STORAGE & HANDLING**

- Use proper stacking procedures to ensure sufficient stability of the materials.
- Surfaces may be slippery when wet, or due to frost and ice build-up. Exercise caution to prevent falls.
- Exercise care when working near edge of roof.
- Store Mule-Hide membrane in original wrappings in a cool, shaded area. Cover with light colored, breathable, waterproof tarpaulins.
- Pre-Taped membranes should not be exposed to prolonged jobsite storage temperatures in excess of 90°F (32°C), otherwise the shelf life of the Pre-Tape may be affected.
- When using pre-taped membranes in warm, sunny weather, shade the tape end of the rolls until ready to use.
- Mule-Hide Pre-Tape has a shelf life of one year.

## **PROTECTION & SAFETY**

Mule-Hide maintains Safety Data Sheets on all of its non-exempt products. Safety Data Sheets contain health and safety information for your development of appropriate product handling procedures to protect your employees and customers. Mule-Hide's Safety Data Sheets should be read and understood by all of your supervisory personnel and employees before using Mule-Hide products in your facilities.

## **ADDITIONAL INFORMATION**

The information given on this PDS is subject to change without notice. Always check the Mule-Hide website at [www.mulehide.com](http://www.mulehide.com) for the latest information, changes and updates or contact Mule-Hide Products Company at 800-786-1492.

# Product Data Sheet

MULE-HIDE STANDARD REINFORCED AND FR REINFORCED EPDM MEMBRANE

---

## **DISCLAIMER**

The statements provided concerning the material shown are intended as a guide for material usage and are believed to be true and accurate at the time of printing. No statement made by anyone may supersede this information, except when done in writing by Mule-Hide Products Co., Inc. Since the manner of use is beyond our control, Mule-Hide does not authorize anyone to make any warranty of merchantability or fitness for any particular purpose or any other warranty, guarantee or representation, expressed or implied, concerning this material. This product may be eligible for a Mule-Hide warranty, please check the Mule-Hide website at [www.mulehide.com](http://www.mulehide.com) or contact Mule-Hide directly at 800-786-1492 for details. Buyer and user accept the product under these conditions and assume the risk of any failure, any injury person or property (including that of the user), loss or liability resulting from the handling, storage or use of the product whether or not it is handled, stored or used in accordance with the directions or specifications. Mule-Hide must be notified in writing of any claims and be given the opportunity to inspect the alleged failure before repairs are made.



# MULE-HIDE DRILL POINT FASTENERS

## PRODUCT DESCRIPTION

Rev. May 2020

Mule-Hide Drill Point Fasteners are # 12 fasteners that are specifically engineered to attached insulation, cover boards and base sheets to wood and steel decking (16 to 22 gauge). These fasteners incorporate a No. 3 Phillips recess, flat truss head with a #2 double flute self-drilling point. The drill point has an exclusive tapered entry thread design that allows for fastener penetration into steel roof decks and offers exceptional back-out resistance.

## BASIC USES

Mule-Hide's Drill Point Fasteners are designed specifically for the mechanical attachment of Mule-Hide's Poly ISO 1 and Poly ISO 2 roof insulation boards and other FM approved insulation / cover boards into steel and wood decks. The Mule-Hide Drill Point Fasteners may be used in conjunction with the Mule-Hide 3" Insulation Plates. Refer to Mule-Hide's appropriate Single-Ply Manuals for installation instructions and uses.

## SPECIFICATIONS

Property	Standard	Average Ultimate Value
Wire:	----	SAE C-1022, heat treated wire
Coating:	----	TRU-Kote™ Epoxy E-Coat
Corrosion Resistance	FM 4470, ASTM D6294, DIN 50018	<15% Red Rust after 30 cycles
Tensile Strength	ASTM F606-10	2500 lb.
Shear Strength	NASM 1312-20	1900 lb. (thread zone)

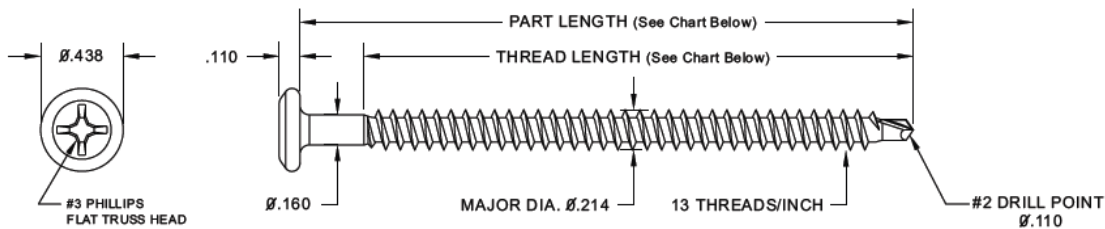

## PACKAGING

Screw Length*	Thread Length*	Pieces/Box x	Weight/Box
1-5/8"	1-5/8"	1000	11.8 lbs
2-1/4"	2-1/4"	1000	16.2 lbs
2-7/8"	2-7/8"	1000	19.7 lbs
3-1/4"	2-7/8"	1000	21.5 lbs
3-3/4"	2-7/8"	1000	24.6 lbs
4-1/2"	3-7/8"	1000	28.8 lbs
5"	3-7/8"	1000	31.5 lbs
6"	3-7/8"	1000	37.1 lbs
7"	3-7/8"	500	20.9 lbs
8"	3-7/8"	500	23.9 lbs

Screw Length and Thread Length are ± 1/16"

# MULE-HIDE DRILL POINT FASTENERS

## PERFORMANCE INFORMATION

Average Ultimate Pullout Values in Corrugated Steel Deck Substrates														
Thickness	24 ga.			22 ga.			20 ga.			18 ga.			16 ga.	
Strength, ksi	36.5	33.0	80.0	102.0	33.0	80.0	102.0	33.0	80.0	102.0	33.0	80.0	102.0	
Pullout (lbs)	230	285	410	465	355	505	580	540	715	800	710	1000	1142	

Average Ultimate Pullout Values in Wood Substrates								
Type	APA Rated OSB				APA Rated Plywood			SPF #2
Thickness	7/16"	15/32"	19/32"	23/32"	15/32"	19/32"	23/32"	
Pullout (lbs)	265	300	325	440	365	475	720	700*

- \*lbf./in. of thread penetration including tip.
- Pull out values are offered only as a guide and are not guaranteed in any way.
- Designated holding powers are dependent upon quality of substrate and accuracy of installation.
- Mule-Hide recommends that fastener pull out testing be performed to verify fastener performance.

## CODE APPROVALS/COMPLIANCE

Mule-Hide Drill Point Fasteners comply with the requirements of the following specifications, test and code requirements when properly installed.

\* FM Standard 4450/4470 Approval    \* Metro-Dade Approved    \*Florida Product Approval

LEED® Information	
Manufacturing Location	Bryan, OH
LEED Eligible Recycle Content	20%

## INSTALLATION INSTRUCTIONS

### **Steel and Wood Decks**

Install fasteners with #3 Phillips drive bit provided in box and a variable speed screw gun. Fastener must penetrate the deck a minimum of 3/4" as measured from the underside of the roof deck to the fastener tip. Ensure that fastener is installed perpendicular to surface of roof deck. Care should be taken to not overdrive the fastener causing damage to roof insulation, fastener or roof deck.

Use eye protection when installing fasteners.

## PROTECTION & SAFETY

Mule-Hide maintains Safety Data Sheets on all of its non-exempt products. Safety Data Sheets contain health and safety information for your development of appropriate product handling procedures to protect your employees and customers. Mule-Hide's Safety Data Sheets should be read and understood by all of your supervisory personnel and employees before using Mule-Hide products in your facilities.

## ADDITIONAL INFORMATION

The information given on this PDS is subject to change without notice. Always check the Mule-Hide website at [www.mulehide.com](http://www.mulehide.com) for the latest information, changes and updates or contact Mule-Hide Products Company at 800-786-1492.

## DISCLAIMER

The statements provided concerning the material shown are intended as a guide for material usage and are believed to be true and accurate at the time of printing. No statement made by anyone may supersede this information, except when done in writing by Mule-Hide Products Co., Inc. Since the manner of use is beyond our control, Mule-Hide does not authorize anyone to make any warranty of merchantability or fitness for any particular purpose or any other warranty, guarantee or representation, expressed or implied, concerning this material. This product may be eligible for a Mule-Hide warranty, please check the Mule-Hide website at [www.mulehide.com](http://www.mulehide.com) or contact Mule-Hide directly at 800-786-1492 for details. Buyer and user accept the product under these conditions and assume the risk of any failure, any injury person or property (including that of the user), loss or liability resulting from the handling, storage or use of the product whether or not it is handled, stored or used in accordance with the directions or specifications. Mule-Hide must be notified in writing of any claims and be given the opportunity to inspect the alleged failure before repairs are made.



# MULE-HIDE HDP (#14) FASTENERS

## PRODUCT DESCRIPTION

Rev. May 2020

Mule-Hide Heavy-Duty Drill Point Fasteners are # 14 fasteners that are specifically engineered to attached insulation, cover boards and base sheets to wood and steel decking (16 to 22 gauge). These fasteners incorporate a No. 3 Phillips recess, flat truss head with a #2 double flute self-drilling point. The drill point has an exclusive tapered entry thread design that allows for fastener penetration into steel roof decks and offers exceptional back-out resistance.

## BASIC USES

Mule-Hide's HDP Fasteners are designed specifically for the mechanical attachment of Mule-Hide's reinforced EPDM, TPO and PVC membranes and for the mechanical attachment of Poly ISO 1 and Poly ISO 2 roof insulation boards and other FM approved insulation / cover boards into steel, wood and concrete decks. The Mule-Hide HDP Fasteners may be used in conjunction with the Mule-Hide 2.4" Seam Plates, 3" Insulation Plates and All Purpose Bars. Refer to Mule-Hide's appropriate Single-Ply Manuals for installation instructions and uses.



## SPECIFICATIONS

Property	Standard	Average Ultimate Value
Wire:	----	SAE C-1022, heat treated wire
Coating:	----	TRU-Kote™ Epoxy E-Coat
Corrosion Resistance	FM 4470, ASTM D6294, DIN 50018	<15% Red Rust after 30 cycles
Tensile Strength	ASTM F606-10	3200 lbf.
Shear Strength	NASM 1312-20	2200 lb. (thread zone)

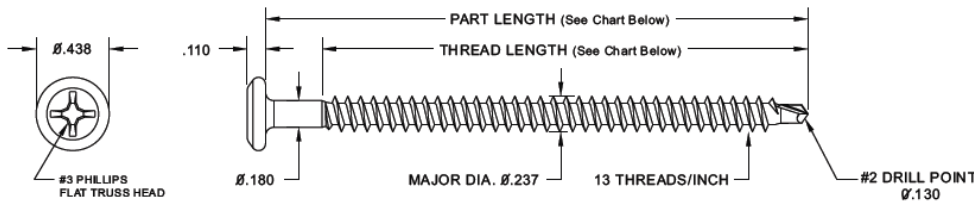

## PACKAGING

Screw Length*	Thread Length*	Pieces/Box	Weight/Box
1-1/2"	1-1/2"	1000	12.9 lbs
2"	2"	1000	15.5 lbs
2-1/2"	2-1/2"	1000	19.4 lbs
3"	2-7/8"	1000	23.7 lbs
3-1/2"	2-7/8"	1000	26.4 lbs
4"	3-7/8"	1000	30.9 lbs
4-1/2"	3-7/8"	1000	33.6 lbs
5"	3-7/8"	1000	37.3 lbs
5-1/2"	3-7/8"	1000	40.8 lbs
6"	3-7/8"	1000	44.0 lbs
7"	3-7/8"	500	25.9 lbs
8"	3-7/8"	500	29.7 lbs
9"	3-7/8"	250	16.6 lbs
10"	3-7/8"	250	18.5 lbs
11"	3-7/8"	250	20.1 lbs
12"	3-7/8"	250	22.0 lbs

\*Notes: Screw Length is ± 1/16" Thread Length is ± 1/16"



# MULE-HIDE HDP (#14) FASTENERS

## Performance Information

Average Ultimate Pullout Values in Corrugated Steel Deck Substrates															
Thickness	24 ga.			22 ga.			20 ga.			18 ga.			16 ga.		
Strength, ksi	36.5	33.0	80.0	102.0	33.0	80.0	102.0	33.0	80.0	102.0	33.0	80.0	102.0		
Pullout (lbs)	255	315	480	560	420	615	710	675	885	985	850	1115	1240		

Average Ultimate Pullout Values in Wood Substrates									Concrete	
Type	APA Rated OSB				APA Rated Plywood				SPF #2	3,000 psi
Thickness	7/16"	15/32"	19/32"	23/32"	15/32"	19/32"	23/32"			
Pullout (lbs)	270	290	310	410	360	410	730	795*	450*	

- \*lbf./in. of thread penetration including tip.
- Pull out values are offered only as a guide and are not guaranteed in any way.
- Designated holding powers are dependent upon quality of substrate and accuracy of installation.
- Mule-Hide recommends that fastener pull out testing be performed to verify fastener performance.

## CODE APPROVALS/COMPLIANCE

Mule-Hide HDP Fasteners comply with the requirements of the following specifications, test and code requirements when properly installed. FM Standard 4450/4470 Approved, Metro-Dade Approved, Florida Product Approvals.

LEED® Information	
Manufacturing Location	Bryan, OH
LEED Eligible Recycle Content	20%

## INSTALLATION INSTRUCTIONS

### Steel and Wood Decks

Install fasteners with #3 Phillips drive bit provided in box and a variable speed screw gun. Fastener must penetrate the deck a minimum of 3/4" as measured from the underside of the roof deck to the fastener tip. Ensure that fastener is installed perpendicular to surface of roof deck. Care should be taken to not overdrive the fastener causing damage to roof insulation, fastener or roof deck.

### Concrete Decks

Pre-drill a 3/16" diameter hole using a drill bit that meets ANSI Standard B212.15 requirements and hammer drill. Drill hole a minimum of 1/2" deeper than fastener embedment and clean debris from hole. Using the #3 Phillips drill bit provided and a 0 to 1500 rpm screw gun, install fastener to a minimum embedment of 1" until fastener head is properly seated in bar or plate. Care should be taken to not overdrive the fastener causing damage to roof insulation, fastener or roof deck. **Use eye protection when installing fasteners.**

## PROTECTION & SAFETY

Mule-Hide maintains Safety Data Sheets on all of its non-exempt products. Safety Data Sheets contain health and safety information for your development of appropriate product handling procedures to protect your employees and customers. Mule-Hide's Safety Data Sheets should be read and understood by all of your supervisory personnel and employees before using Mule-Hide products in your facilities.

## ADDITIONAL INFORMATION

The information given on this PDS is subject to change without notice. Always check the Mule-Hide website at [www.mulehide.com](http://www.mulehide.com) for the latest information, changes and updates or contact Mule-Hide Products Company at 800-786-1492.

## DISCLAIMER

The statements provided concerning the material shown are intended as a guide for material usage and are believed to be true and accurate at the time of printing. No statement made by anyone may supersede this information, except when done in writing by Mule-Hide Products Co., Inc. Since the manner of use is beyond our control, Mule-Hide does not authorize anyone to make any warranty of merchantability or fitness for any particular purpose or any other warranty, guarantee or representation, expressed or implied, concerning this material. This product may be eligible for a Mule-Hide warranty, please check the Mule-Hide website at [www.mulehide.com](http://www.mulehide.com) or contact Mule-Hide directly at 800-786-1492 for details. Buyer and user accept the product under these conditions and assume the risk of any failure, any injury person or property (including that of the user), loss or liability resulting from the handling, storage or use of the product whether or not it is handled, stored or used in accordance with the directions or specifications. Mule-Hide must be notified in writing of any claims and be given the opportunity to inspect the alleged failure before repairs are made.



# Product Data Sheet

## MULE-HIDE BONDING ADHESIVE

### PRODUCT DESCRIPTION

Mule-Hide Bonding Adhesive is a high strength solvent-based contact adhesive that allows quick bonding of EPDM membrane and cured flashings to various porous and non-porous substrates. May be used on both horizontal and vertical surfaces. Formulated for application with a ½" (13 mm) medium nap roller.

### BASIC USES

Mule-Hide Bonding Adhesive is used for bonding cured flashings and membranes to a variety of substrates.

### TYPICAL PHYSICAL PROPERTIES

Typical values*	
Base Material	Synthetic Rubber
Color	Yellow
Solids	18 - 22%
VOC:	660 g/l max
Flash Point	-4° F (-20° C) Closed Cup
Brookfield Viscosity	3,200 Centipoises
Avg Net Weight	7.1 lbs. / gallon (0.85 Kg/L)
Packaging	5 Gallon Pails
Shelf Life	1 Year



\*General properties. Typical properties and characteristics are based on samples tested and are not guaranteed for all samples of this product. This data and information is intended as a guide and does not reflect the specification or specification range for any particular property of this product.

### PACKAGING

5 Gallon Pails

### BENEFITS & SUPPLEMENTAL STATEMENTS

- High strength adhesive with quick bonding characteristics
- Ease of application with a medium nap roller
- Provides excellent adhesion between EPDM membranes and a variety of substrates

### CODE APPROVALS/COMPLIANCE

A variety of Factory Mutual Ratings and Underwriter Laboratory Classifications are available. Contact Mule-Hide Technical Department for additional information.

### COVERAGE RATES

Coverage for Mule-Hide Bonding Adhesive is approximately 60 ft<sup>2</sup> (5.6 square m) per gallon (finished surface.) This coverage rate is an average and may vary due to conditions on the job site. Porous surfaces and substrates may require more bonding adhesive than the typical coverage rate.

### INSTALLATION TEMPERATURE

If adhesive is store at temperatures less than 60° F, restore to room temperature (~70° F) before using.



# Product Data Sheet

## MULE-HIDE BONDING ADHESIVE

### INSTALLATION INSTRUCTIONS

#### Surface Preparation

1. The surface, on or against which adhesive is to be applied, shall be clean, smooth, dry, free of fins, sharp edges, loose and foreign materials, oil and grease. Depressions greater than 1/4" (6 mm) should be feathered; using epoxy, mortar or other approved patching material. All sharp projections shall be removed by sweeping, blowing or vacuum cleaning.

#### Application

1. Stir thoroughly until all settled pigments are dispersed and product is uniform in color. After stirring (minimum 5 minutes) apply Mule-Hide Bonding Adhesive to substrate and membrane using a 9" (230 mm) wide, 1/2" (13 mm) medium nap roller. Application shall be continuous and uniform avoiding globs or puddles. Mule-Hide Bonding Adhesive must be allowed to dry until it does not string or stick to a dry finger touch. Any coated area, which has been exposed to rain, should be allowed to dry and then recoated.  
**Do not apply adhesive to seam areas or use with taped products.**
2. Roll the membrane onto the adhesive coated substrate while avoiding wrinkles. Immediately brush down the bonded portion of the sheet with a soft bristle push broom or a clean dry roller applicator to achieve maximum contact. In some applications, swelling of the membrane may occur initially, but this will disappear after several days' exposure. Do not re-broom membrane in an attempt to remove swelling.

REVIEW CURRENT MULE-HIDE SPECIFICATIONS AND DETAILS FOR SPECIFIC APPLICATION REQUIREMENTS.

#### Precautions

1. Review the applicable Material Safety Data Sheet for complete safety information prior to use.
2. Mule-Hide Bonding Adhesive is **EXTREMELY FLAMMABLE** -It contains solvents that are dangerous fire and explosion hazards when exposed to heat, flame or sparks. Do not smoke while applying. Do not use in a confined or unventilated area. Vapors are heavier than air and may travel along ground or may be moved by ventilation and ignited by pilot lights, other flames, sparks, heaters, smoking, electrical motors, static discharge, or other ignition sources at locations distant from material handling point and flashback. All containers should be grounded when material is transferred from one container to another. A red caution label is required when shipping. A fire extinguisher should be available. In case of fire, use water spray, foam, dry chemical or carbon dioxide. Do not use a solid stream of water because it can scatter and spread the fire.
3. Avoid breathing vapors. Keep container closed when not in use. Use with adequate ventilation. If inhaled, remove to fresh air. If not breathing, perform artificial respiration. If breathing is difficult, give oxygen. Call a physician immediately. During application, efforts must be made to prevent fumes from entering the building via air ventilation ducts. Do not place open containers or mix adhesive near fresh air intake units. When possible, shut down or seal off the closest units.
4. If swallowed, **DO NOT INDUCE VOMITING**. Call a physician immediately.
5. Avoid contact with skin. Wash hands thoroughly after handling. In case of contact with skin, thoroughly wash affected area with soap and water. Contact physician if irritation persists. **Note:** Permeation resistant gloves (that meet ANSI/ISEA 105-2005) are recommended to be worn when using this product to protect hands from irritating ingredients.



# Product Data Sheet

## MULE-HIDE BONDING ADHESIVE

### Precautions (continued)

6. Avoid contact with eyes. Safety glasses or goggles are recommended. If splashed in eyes, immediately flush eyes with plenty of clean water for at least 15 minutes. Contact a physician immediately.
7. Do not thin Mule-Hide Bonding Adhesive. Thinning will affect performance. Excessively thick or gelled material should be discarded.
8. Job site storage in excess of 90°F (32°C) may affect product shelf life. Should the Mule-Hide Bonding Adhesive be stored at temperatures lower than 60°F (15°C), restore to room temperature prior to use.
9. These materials are sensitive to ambient moisture and heat will accelerate the effect of moisture. Opened containers of Bonding Adhesive should be used within 48 hours. Adhesive will begin to thicken after this point, making it difficult and eventually impossible, to control adhesive thickness. In hot weather, do not leave sealed containers on roof for prolonged periods of time. In cold weather, keep material at room temperature until ready to use. Stir adhesive occasionally while using.
10. Coverage rates are an average and may vary due to jobsite conditions.

### 11. KEEP OUT OF THE REACH OF CHILDREN

### STORAGE & HANDLING

Job site storage in excess of 90°F (32°C) may affect product shelf life. Should the Mule-Hide Bonding Adhesive be stored at temperatures lower than 60°F (15°C), restore to room temperature prior to use.

### PROTECTION & SAFETY

Mule-Hide maintains Safety Data Sheets on all of its non-exempt products. Safety Data Sheets contain health and safety information for your development of appropriate product handling procedures to protect your employees and customers. Mule-Hide's Safety Data Sheets should be read and understood by all of your supervisory personnel and employees before using Mule-Hide products in your facilities.

### ADDITIONAL INFORMATION

The information given on this PDS is subject to change without notice. Always check the Mule-Hide website at [www.mulehide.com](http://www.mulehide.com) for the latest information, changes and updates or contact Mule-Hide Products Company at 800-786-1492.

### DISCLAIMER

The statements provided concerning the material shown are intended as a guide for material usage and are believed to be true and accurate at the time of printing. No statement made by anyone may supersede this information, except when done in writing by Mule-Hide Products Co., Inc. Since the manner of use is beyond our control, Mule-Hide does not authorize anyone to make any warranty of merchantability or fitness for any particular purpose or any other warranty, guarantee or representation, expressed or implied, concerning this material. This product may be eligible for a Mule-Hide warranty, please check the Mule-Hide website at [www.mulehide.com](http://www.mulehide.com) or contact Mule-Hide directly at 800-786-1492 for details. Buyer and user accept the product under these conditions and assume the risk of any failure, any injury person or property (including that of the user), loss or liability resulting from the handling, storage or use of the product whether or not it is handled, stored or used in accordance with the directions or specifications. Mule-Hide must be notified in writing of any claims and be given the opportunity to inspect the alleged failure before repairs are made.



# Product Data Sheet

## LOW-VOC BONDING ADHESIVE

### PRODUCT DESCRIPTION

Low-VOC Bonding Adhesive is a high strength solvent-based contact adhesive that allows bonding of EPDM and TPO membrane to various porous and non-porous substrates. It is specially formulated using a blend of VOC exempt and non-exempt solvents to meet the < 250 g/l VOC content requirements of the OTC Model Rule for Single Ply Roofing Adhesives. Low-VOC Bonding Adhesive is easily applied with a 9" (228 mm) medium nap roller to create a strong bond between the membrane and approved substrate.

**This product does not comply with the following California counties' VOC regulations:** Alameda, Contra Costa, El Dorado, Los Angeles, Marin, Napa, Orange, Riverside, Sacramento, San Bernardino, San Diego, San Francisco, San Mateo, Santa Clara, Solano, Sonoma, and Tehama. These areas require the use of Mule-Hide Low-VOC 1168 Bonding Adhesive.



### BASIC USES

Mule-Hide Bonding Adhesive is used for bonding (cured) flashings and membranes to a variety of substrates.

### TYPICAL PHYSICAL PROPERTIES

Typical values*	
Base Material	Synthetic Rubber
Color	Yellow
Solids	22%
VOC:	250 g/l max
Flash Point	0° F (-17° C) Closed Cup
Brookfield Viscosity	3,500 Centipoises
Avg Net Weight	8 lbs. / gallon (0.96 kg/l)
Packaging	5 Gallon Pails & 1 Gallon Cans
Shelf Life	1 Year

LEED Information	
Pre-consumer Recycled Content	0%
Post-consumer Recycled Content	0%
Manufacturing Location	Carlisle, PA
VOC Content	< 250 g/l

\*General properties. Typical properties and characteristics are based on samples tested and are not guaranteed for all samples of this product. This data and information is intended as a guide and does not reflect the specification or specification range for any particular property of this product.

### PACKAGING

Packaged in 5 gallon pails and 1 gallon cans

### BENEFITS & SUPPLEMENTAL STATEMENTS

- High strength adhesive with quick bonding characteristics
- Ease of application with a medium nap roller
- Provides excellent adhesion between TPO or EPDM membranes and a variety of substrates
- Extended open time

### CODE APPROVALS/COMPLIANCE

A variety of Factory Mutual Ratings and Underwriter Laboratory Classifications are available. Contact Mule-Hide Technical Department for additional information.

# Product Data Sheet

LOW-VOC BONDING ADHESIVE

---

## COVERAGE RATES

Coverage for Low-VOC Bonding Adhesive is approximately 60 ft<sup>2</sup> (5.6 square m) per gallon (finished surface.) A 5-gallon pail should cover no more than 300 square feet (28 m<sup>2</sup> of finished area. This coverage rate is an average and may vary due to conditions on the job site. Porous wall substrates such as masonry block may require two coats of bonding adhesive. In these cases, allow the first coat of adhesive to flash off completely prior to applying the second coat of adhesive at the required coverage rate of 60 square feet per gallon.

## INSTALLATION TEMPERATURE

If adhesive is stored below freezing temperatures, restore to room temperature for a minimum of 24 hours prior to use. Keep adhesive warm (60°F to 90°F, 15°C to 32°C) for ease of application.

## INSTALLATION INSTRUCTIONS

### Surface Preparation

The surface, on or against which adhesive is to be applied, shall be clean, smooth, dry, free of fins, sharp edges, loose and foreign materials, oil and grease. Depressions greater than 1/4" (6 mm) should be feathered; using epoxy, mortar or other approved patching material. All sharp projections shall be removed by sweeping, blowing or vacuum cleaning.

### Mixing

**Stir Low-VOC Bonding Adhesive thoroughly once per day until all settled polymers are dispersed and the adhesive is a uniform yellow color. During mixing, scrape the sides and bottom of the pail until the adhesive is a uniform yellow color with no dark streaks. Keeping the adhesive warm, as well as using an air-operated mixing paddle, will aid in the mixing process.**

### Application

1. Allow membrane to relax for half an hour or longer. Allowing the membrane to relax will result in the roof's surface having a smoother appearance. This is especially true for sheets that have folds or creases.
2. After the Low-VOC Bonding Adhesive has been thoroughly mixed, apply to the substrate and membrane using a 9" (228 mm) medium nap roller. Application shall be continuous and uniform, avoiding globs or puddles that could result in solvent blisters. Heavy "wet" areas can be re-rolled to break the skin, allowing the solvents to flash off. The solvents in Low-VOC Bonding Adhesive must be allowed to flash-off until the adhesive does not string or transfer to a dry finger touch, but remains tacky. This is called the "tack test". It's recommended to continually monitor the adhesive for flash-off after the application of the adhesive. **Install the membrane after the adhesive passes the tack test to avoid trapped solvent blisters. In hot weather, flash-off time can occur in as little as 5 minutes or less. Temperature, sun, shade or humidity can affect flash-off time.** Any coated area, which has been exposed to rain, should be allowed to dry and then recoated. **Do not apply adhesive to seam areas or use with taped products.**
3. Roll the membrane onto the adhesive-coated substrate while avoiding wrinkles. Immediately brush down the bonded portion of the sheet with a stiff-bristle push broom to achieve maximum contact. For wall applications, use a neoprene type hand roller after brooming to ensure maximum contact. If blisters occur from trapped solvent, allow the solvent to naturally dissipate for 4 or 5 days and then re-roll or re-broom the membrane so it lays flat.

REVIEW CURRENT MULE-HIDE SPECIFICATIONS AND DETAILS FOR ADDITIONAL INFORMATION.

# Product Data Sheet

## LOW-VOC BONDING ADHESIVE

---

### Precautions

1. Review the applicable Material Safety Data Sheet for complete safety information prior to use.
2. Low-VOC Bonding Adhesive must be stored in original, unopened containers at temperatures between 60°F (15°C) and 90°F (32°C). Jobsite storage in excess of 90°F (32°C) may affect product shelf life.
3. Prolonged exposure to below freezing temperatures will cause the adhesive to thicken and solidify in the can. Should the Low-VOC Bonding Adhesive be stored at temperatures lower than 25°F (-4°C), restore to room temperature for a minimum of 24 hours prior to use. Adhesive will perform as intended once it is returned to a liquid state. When temperatures are expected to be consistently below 40°F (4°C), a heated enclosure or hot box is required for storage. Keep the adhesive warm (60-90°F) for ease of application.
4. Low-VOC Bonding Adhesive is **EXTREMELY FLAMMABLE** -It contains solvents that are dangerous fire and explosion hazards when exposed to heat, flame or sparks. Do not smoke while applying. Do not use in a confined or unventilated area. Vapors are heavier than air and may travel along ground or may be moved by ventilation and ignited by pilot lights, other flames, sparks, heaters, smoking, electrical motors, static discharge, or other ignition sources at locations distant from material handling point and flashback. All containers should be grounded when material is transferred from one container to another. A red caution label is required when shipping. A fire extinguisher should be available. In case of fire, use water spray, foam, dry chemical or carbon dioxide. Do not use a solid stream of water because it can scatter and spread the fire.
5. Avoid breathing vapors. Keep container closed when not in use. Use with adequate ventilation. If inhaled, remove to fresh air. If not breathing, perform artificial respiration. If breathing is difficult, give oxygen. Call a physician immediately. During application, efforts must be made to prevent fumes from entering the building via air ventilation ducts. Do not place open containers or mix adhesive near fresh air intake units. When possible, shut down or seal off the closest units.
6. If swallowed, **DO NOT INDUCE VOMITING**. Call a physician immediately.
7. Avoid contact with skin. Wash hands thoroughly after handling. In case of contact with skin, thoroughly wash affected area with soap and water. Contact physician if irritation persists. **Note:** Permeation resistant gloves (that meet ANSI/ISEA 105-2005) are recommended to be worn when using this product to protect hands from irritating ingredients.
8. Avoid contact with eyes. Safety glasses or goggles are recommended. If splashed in eyes, immediately flush eyes with plenty of clean water for at least 15 minutes. Contact a physician immediately.
9. Do not thin Low-VOC Bonding Adhesive. Thinning will affect performance. Excessively thick or gelled material should be discarded.
10. These materials are sensitive to ambient moisture and heat will accelerate the effect of moisture. Opened containers of bonding adhesive should be used within 48 hours. Adhesive will begin to thicken after this point, making it difficult, and eventually impossible, to control adhesive thickness.
11. Adhesive must be allowed to flash-off but not become over dry. If membrane is mated with the substrate prior to the adhesive being dry, blistering will occur. If membrane is mated with the substrate after the adhesive has over-dried, loose or unadhered areas will occur. Thin application of adhesive increases risk of over-drying.
12. Coverage rates are an average and may vary due to jobsite conditions.
13. **KEEP OUT OF THE REACH OF CHILDREN**



# Product Data Sheet

LOW-VOC BONDING ADHESIVE

---

## **STORAGE & HANDLING**

Job site storage in excess of 90°F (32°C) may affect product shelf life. Should the Low-VOC Bonding Adhesive be stored at temperatures lower than 60°F (15°C), restore to room temperature prior to use.

Prolonged exposure to below freezing temperatures will cause the adhesive to thicken and solidify in the can. Should the Low-VOC Bonding Adhesive be stored at temperatures lower than 25°F (-4°C), restore to room temperature for a minimum of 24 hours prior to use. Adhesive will perform as intended once it is returned to a liquid state. When temperatures are expected to be consistently below 40°F (4°C), a heated enclosure or hot box is required for storage. Keep the adhesive warm (60-90°F) for ease of application.

## **PROTECTION & SAFETY**

Mule-Hide maintains Material Safety Data Sheets on all of its products. Material Safety Data Sheets contain health and safety information for your development of appropriate product handling procedures to protect your employees and customers. Mule-Hide's Material Safety Data Sheets should be read and understood by all of your supervisory personnel and employees before using Mule-Hide products in your facilities.

## **ADDITIONAL INFORMATION**

The information given on this PDS is subject to change without notice. Always check the Mule-Hide website at [www.mulehide.com](http://www.mulehide.com) for the latest information, changes and updates or contact Mule-Hide Products Company at 800-786-1492.

## **DISCLAIMER**

The statements provided concerning the material shown are intended as a guide for material usage and are believed to be true and accurate at the time of printing. No statement made by anyone may supersede this information, except when done in writing by Mule-Hide Products Co., Inc. Since the manner of use is beyond our control, Mule-Hide does not authorize anyone to make any warranty of merchantability or fitness for any particular purpose or any other warranty, guarantee or representation, expressed or implied, concerning this material. This product may be eligible for a Mule-Hide warranty, please check the Mule-Hide website at [www.mulehide.com](http://www.mulehide.com) or contact Mule-Hide directly at 800-786-1492 for details. Buyer and user accept the product under these conditions and assume the risk of any failure, any injury person or property (including that of the user), loss or liability resulting from the handling, storage or use of the product whether or not it is handled, stored or used in accordance with the directions or specifications. Mule-Hide must be notified in writing of any claims and be given the opportunity to inspect the alleged failure before repairs are made.





# AeroWeb

## Low-VOC Aerosol Contact Adhesive



### PRODUCT DATA SHEET



#### ACCEPTABLE MEMBRANES AND APPLICATIONS

Membrane	Wall	Field
TPO	Yes	Yes
EPDM	Yes	Yes*
PVC	No	No
Fleece Back**	Yes	No

\*Contact Mule-Hide Technical Department for project requirements

\*\*Not for use with TPO Fleece Back FR

#### PACKAGING

PRODUCT	SIZE/WEIGHT
AeroWeb	#40 Aerosol Cylinder Fill Weight: 30 lbs. of Adhesive
6' Hose	6' Length
12' Hose	12' Length
18' Hose	18' Length
Spray Gun Adjustable	--
Spray Gun with 24" Extension	--
Low-VOC Un-Tack	#8 Aerosol Cylinder

**Important Note:** AeroWeb, Low-VOC Un-Tack, hoses and gun are each sold separately.

#### DESCRIPTION

Mule-Hide's AeroWeb Low-VOC Aerosol Contact Adhesive/Primer can be used for a variety of applications: adhering Fleece Back, Standard TPO, and EPDM membrane to vertical walls, enhancing the bond between Mule-Hide's F5 and various substrates, and priming unexposed asphalt prior to applying Helix Adhesive for insulation attachment.

AeroWeb's Low-VOC, methylene chloride-free formula promotes tenacious adhesion and quick drying in a wide range of temperatures. Applied using a self-contained spray system that provides quick and even coverage, this system requires minimal cleanup or maintenance.

**Please note: cylinder, hoses, and gun are each sold separately.**

#### PRODUCTIVITY BOOSTING FEATURES AND BENEFITS

- Quick application with spray gun
- Fast tack time
- No stirring
- Up to 60% labor savings compared to traditional bonding adhesive

#### FEATURES AND BENEFITS

- Adhering Fleece Back (vertical application only)
- Can be used in temperatures as low as 25°F when used as an adhesive
- Can be used in temperatures as low as 15°F when used as a primer
- Easy setup
- Easy cleanup
- Low odor and Low-VOC

#### INSTALLATION INSTRUCTIONS

1. Connect spray gun to hose and connect hose to cylinder. Use lithium grease or petroleum jelly on all fittings and be careful to avoid cross-threading. Open valve on cylinder to check fittings for leaks. Keep cylinder valve open to maintain pressure in the hose/spray gun when not in use.
2. AeroWeb can be applied at ambient temperature of 25°F and above. Propellant in cylinders must be kept above 70°F for the product to spray properly. Utilize power-heated blanket, and hot boxes when necessary. Substrate shall be clean, dry, and free of debris and contaminants.
3. For applications taking place in ambient temperature below 70°F, store cylinders in heated space and move to project area during application. Cylinders must be kept warm on the jobsite. Dispense product from cylinder while it is still warm. When product in cylinder becomes too cold, it will begin to spit rather than spray. If this occurs, swap cold cylinder for warmer one and return cold cylinder to heated area. When changing cylinder, close the valve on the cylinder and depressurize the hose. Remove the hose and attach to the new cylinder. Open valve and do a test spray.
4. Apply AeroWeb in an even coat to substrate (refer to the drawing on the next page), keeping the spray tip approximately 12" (30.5 cm) away and perpendicular to the surface during spray. Avoid high thickness buildup.



# AeroWeb

## Low-VOC Aerosol Contact Adhesive



### PRODUCT DATA SHEET

5. Allow AeroWeb to flash-off until it does not transfer to finger when touched. Limit application of AeroWeb to surfaces that will be covered with membrane or Mule-Hide's F5 the same day.

#### Vertical Applications of Standard TPO & EPDM membrane, or any Fleece Back membrane\*:

(\*Note: Not for use with TPO Fleece Back FR)

Acceptable substrates include: Mule-Hide Poly ISO roof insulation, Poly ISO 1-HD, DensDeck® Prime, SECUROCK®, OSB, plywood, metal, residual asphalt, and clean concrete block. To improve adhesion and reduce the potential for asphalt bleed-through on vertical surfaces with residual asphalt, apply an initial "sealing" base coat of AeroWeb and allow to flash off properly; then, apply a secondary coating of AeroWeb to the vertical surface.

There are no height restrictions when using AeroWeb for vertical applications if the appropriate membrane terminations are utilized.

1. Spray wall and back of the membrane, utilizing a 50% overlapping spray pattern.
2. Do not apply adhesive to splice areas.
3. Allow adhesive to become tacky but not overly dry; it should not transfer to fingers when touched.
4. Mate membrane with the wall from the center of the sheet towards the edges, smoothing by hand.
5. Broom the membrane with a soft-bristle broom.
6. Roll in with a hand roller.

#### Horizontal Application of Standard TPO, Standard EPDM and White-on-Black EPDM membranes

Acceptable substrates include: Mule-Hide Poly ISO roof insulation, Poly ISO 1-HD, DensDeck Prime, SECUROCK, OSB, and plywood. Please see Mule-Hide's TPO Specification for a complete list of acceptable substrates.

The surface, on or against which adhesive is to be applied, shall be clean, smooth, dry, free of films, sharp edges, loose and foreign materials, oil and grease. Depressions greater than 1/4" (6 mm) should be feathered, using epoxy, mortar or other approved patching material. All sharp projections shall be removed by sweeping, blowing or vacuum cleaning.

Application shall be continuous and uniform, avoiding globs or puddles.

1. Spray substrate and back of the membrane with enough overlap to ensure 100% coverage (2"-3" of overlap).
2. Do not apply adhesive to splice areas.
3. Allow adhesive to become tacky but not overly dry; it should not transfer to fingers when touched.
4. Roll the membrane onto the adhesive-coated substrate while avoiding wrinkles. Immediately brush down the bonded portion of the sheet with a soft-bristle push broom, and then roll the membrane with a clean, dry roller (minimum 75 lb. to maximum 150 lb.) to achieve maximum contact.

Review Mule-Hide specifications and details for complete installation information.

#### CLEAN UP

UN-TACK™ safe solvent or mineral spirits can be used to clean tools and surfaces. If the spray gun valve becomes stuck, attach hose and spray gun to cylinder of Citrus Cleaner or UN-TACK and trigger spray gun repeatedly until operation is smooth. If the spray gun is clogged, a small-gauge wire or torch clean-out tool is helpful after soaking the brass fitting in UN-TACK.

#### STORAGE AND HANDLING

Store cylinders in protected, conditioned space with temperature maintained above 70°F. Do not store cylinders in areas where temperatures reach 110°F or higher. Contents are flammable. Store in accordance with local, state, and federal regulations. Keep cylinder valve open to maintain pressure in the hose and spray gun. Periodically spray in a safe manner to help prevent possible clogging. Keep spray gun trigger locked when not in use. Flush gun and hose with UN-TACK for long-term storage beyond 30 days.

TYPICAL PROPERTIES AND CHARACTERISTICS	
PHYSICAL PROPERTY	TYPICAL VALUE
Color	Light Green
Consistency	Aerosol Spray
Spray Pattern	Variable Web
Odor	Low
Base	Rubber/Solvent Blend
Solvent	Cyclohexane/Acetone
Coverage Rate	1-Sided Primer - 2,000-2,500 ft <sup>2</sup> when used with air and vapor barriers* 2-Sided Adhesive - Walls - 1,000ft <sup>2</sup> * 2-Sided Adhesive - Field - 1,000ft <sup>2</sup> *
Tack Time	5 minutes**
Adhesion	Excellent
Service Temperature	-30°F-200°F (-34°C to 93°C)
Flammability	Flammable when wet. Non-flammable when dry.
Water Resistance	Excellent
Midew Resistance	Excellent
Shelf Life	12 months (unopened container)

\*Approximate Coverage  
\*\*or longer depending on climate conditions

LEED INFORMATION	
Pre-consumer Recycled Content	0%
Post-consumer Recycled Content	0%
Manufacturing Location	Lynchburg, VA
VOC	248 g/L



# AeroWeb

## Low-VOC Aerosol Contact Adhesive



### PRODUCT DATA SHEET

#### PRECAUTIONS

AeroWeb is a flammable liquid propellant and vapor. Vapors are heavier than air and may travel along the ground or may be moved by ventilation and ignited by pilot lights, other flames, sparks, heaters, smoking, electrical motors, static discharge, or other ignition sources at locations distant from the material handling point and flashback. Keep away from open flame. Use with adequate ventilation. Avoid inhalation of spray mist or vapors. Harmful or fatal if swallowed. May cause eye irritation. Keep out of reach of children. Review Safety Data Sheet for complete safety information prior to use. Use of goggles and gloves is required. Aerosol cylinders are not refillable and when empty are harmless and disposable. Dispose according to local codes and laws. Read safety precautions and warnings on cylinder label. Wear gloves and goggles before using this product. Do not aim spray gun at people or animals at any time. PPE Gloves must be used while handling material.

#### CYLINDER DISPOSAL

When all adhesive in the cylinder has been used, close cylinder valve and evacuate hose and spray gun before disconnecting hose from cylinder. If hose is not to be connected to a new cylinder immediately, do not evacuate hose and spray gun to ensure material does not harden in spray gun and hose. Clean up adhesive residue, spray gun, and spray tips with PVC UN-TACK or mineral spirits. In most areas, the empty cylinder can be disposed as an aerosol can or recycled as scrap metal. If disposal is not allowed in your area, contact your distributor for disposal arrangements. Federal law forbids transportation if refilled.

#### PROTECTION & SAFETY

Mule-Hide maintains Safety Data Sheets on all of its non-exempt products. Safety Data Sheets contain health and safety information for your development of appropriate product handling procedures to protect your employees and customers. Mule-Hide's Safety Data Sheets should be read and understood by all of your supervisory personnel and employees before using Mule-Hide products in your facilities.

For industrial professional use only.

#### ADDITIONAL INFORMATION

On projects where a Mule-Hide Standard or Premium Warranty is requested, an authorized Mule-hide representative shall inspect all completed work.

The information given on this PDS is subject to change without notice. Always check the Mule-Hide website at [www.mulehide.com](http://www.mulehide.com) for the latest information, changes and updates or contact Mule-Hide Products Company at 800-786-1492.

#### DISCLAIMER

The statements provided concerning the material shown are intended as a guide for material usage and are believed to be true and accurate at the time of printing. No statement made by anyone may supersede this information, except when done in writing by Mule-Hide Products Co., Inc. Since the manner of use is beyond our control, Mule-Hide does not authorize anyone to make any warranty of merchantability or fitness for any particular purpose or any other warranty, guarantee or representation, expressed or implied, concerning this material. This product may be eligible for a Mule-Hide warranty, please check the Mule-Hide website at [www.mulehide.com](http://www.mulehide.com) or contact Mule-Hide directly at 800-786-1492 for details. Buyer and user accept the product under these conditions and assume the risk of any failure, any injury person or property (including that of the user), loss or liability resulting from the handling, storage or use of the product whether or not it is handled, stored or used in accordance with the directions or specifications. Mule-Hide must be notified in writing of any claims and be given the opportunity to inspect the alleged failure before repairs are made.



# Product Data Sheet

## MULE-HIDE EPDM IN-SEAM TAPE

### PRODUCT DESCRIPTION

Mule-Hide In-Seam Tape is a black or white, butyl rubber-based adhesive in tape form. The product has been formulated to provide high green strength in both shear and peel. Mule-Hide's In-Seam Tape has a clear, durable poly release film for ease of use.

### BASIC USES

Mule-Hide In-Seam Tape was specifically developed for splicing sheets of EPDM membrane together. The In-Seam Tape may be used on Ballasted, Mechanically Attached and Fully Adhered EPDM Roofing Systems.

### TYPICAL PHYSICAL PROPERTIES

Typical Properties and Characteristics	
Color	Black or White
Base	Synthetic Rubber
Roll Size	100' (30 m) long
Thickness	.030" (0.75mm)
Packaging – 3"	4 rolls / carton – 26 lbs (12 Kg)
Packaging – 6"	2 rolls / carton – 26 lbs (12 Kg)
Typical properties and characteristics are based on samples tested and are not guaranteed for all samples of this product. This data and information is intended as a guide and does not reflect the specification or specification range for any particular property of this product.	



### LEED Information

LEED Information	
Pre-consumer Recycled Content	4%
Post-consumer Recycled Content	0%
Manufacturing Location	Greenville, IL
Solar Reflectance Index (SRI)	N/A

### BENEFITS & SUPPLEMENTAL STATEMENTS

- Available in 3" or 6" widths x 100 foot long rolls
- Available in Black or White
- Excellent long-term strength
- Manufactured with a clear poly film
- Greater peel and shear strength

### INSTALLATION INSTRUCTIONS

1. Overlap the EPDM membranes the appropriate amount. For 3" (75 mm) In-Seam Tape, overlap the membranes 4" (100 mm). For 6" (150 mm) In-Seam Tape, overlap the membranes 7" (175 mm).
2. The entire surface where the In-Seam Tape will be applied must be clean. The In-Seam Tape will not adhere to dusted or dirty surfaces. Any residual contamination will be detrimental to the bond strength of the adhesive.





# Product Data Sheet

## MULE-HIDE EPDM IN-SEAM TAPE

### **INSTALLATION INSTRUCTIONS (Continued)**

3. If membrane is very dirty, scrubbing with Weathered Membrane Cleaner may be necessary. This process is essential on membrane that has been exposed for a number of weeks. Allow membrane to dry thoroughly before proceeding.  
Note: Permeation resistant gloves (that meet ANSI/ISEA 105-2005) are required for hand protection when cleaners or primers are being used.
4. Mark the bottom sheet with a crayon approximately ¼" (6 mm) at the edge of the top sheet along the entire splice length as a guide to install the In-Seam Tape.
5. Apply tape primer with Scotch-Brite® pads or clean rags. Scrub the area of the membrane where the In-Seam Tape is to be applied, in a circular motion to achieve a thin, even coating on the membrane. The properly cleaned/primed area will be uniform in color without streaks and free of globs or puddles.  
Note: The use of excessive amounts of Low VOC EPDM Primer will not significantly enhance the adhesion of the Pre-Taped or Taped Product to the EPDM or TPO membrane. Use only the amount necessary to obtain 100% coverage of the area where the tape or adhesive will be applied.
6. Allow the Low VOC EPDM Primer to dry until it does not transfer to a dry finger touch. Prompt installation of the In-Seam Tape or Taped Product as soon as the primer flashes off minimizes potential dust contamination and promotes adhesion in colder weather.
7. Unroll approximately 3' (1 m) of In-Seam Tape. Align the tape with a marked line and press tape down to bottom sheet using firm, even hand pressure. Continue for the length of the splice. Tape roll ends should be overlapped 1" (25 mm). Allow top sheet to rest on poly backing after application. A minimum of 1/8" (3 mm) to a maximum of 1/2" (12 mm) of tape must extend beyond the splice edge. A continuous piece of In-Seam Tape must be used at all field and factory splice intersections.
8. Roll the In-Seam Tape with a 2"-wide hand roller after application to the primed substrate. This will significantly reduce the frequency of air blisters in the completed field seam.
9. Pull the poly backing from the In-Seam Tape beneath the top sheet and allow the top sheet to fall freely onto the exposed tape.
10. Press top sheet onto tape using firm, even hand pressure across the splice towards the splice edge.
11. Immediately roll the splice with a 2"-wide roller using positive pressure. Roll across the splice edge, not parallel to it.
12. The use of Lap Sealant with In-Seam Tape seams is optional except at cut edges of reinforced membrane (exposed scrim reinforcement and tape overlaps), where Lap Sealant must be utilized. Lap Sealant may be applied immediately following the completion of an In-Seam Tape splice for added protection. See Lap Sealant PDS or appropriate detail for more information.
13. Use of In-Seam Tape at temperatures below 40°F will result in reduced adhesion.  
Review Mule-Hide Specifications and details for complete installation information.

### **PRECAUTIONS**

- Avoid prolonged contact with skin. In case of contact with skin, thoroughly wash affected area with soap and water.
- Prolonged jobsite storage temperatures in excess of 90°F (32°C) will shorten product shelf life.
- In warm, sunny weather, keep In-Seam Tape rolls in original box in a shaded area until ready to use.
- Storage and use of In-Seam Tape at temperatures below 40°F (4°C) will result in a loss of tape tack and, in extreme cases, will result in no bond to the substrate. Overnight storage must be available to keep the temperature of the In-Seam Tape at a minimum of 60°F (15°C). Hot boxes for jobsite storage must be provided to maintain a minimum tape temperature of 40°F (4°C).
- In-Seam Tape must be stored in a dry area.
- Due to solvent flash-off, condensation may occur on freshly applied primer when the ambient temperature is near the dew point. If condensation develops, the application of primer and In-Seam Tape must be discontinued as proper adhesion will not be achieved.



# Product Data Sheet

## MULE-HIDE EPDM IN-SEAM TAPE

### **PRECAUTIONS (Continued)**

- Allow the primer surface to dry and apply a thin freshener coat of primer to the previously coated surface and apply In-Seam Tape when conditions allow.
- KEEP OUT OF REACH OF CHILDREN

### **PROTECTION & SAFETY**

Mule-Hide maintains Material Safety Data Sheets on all of its products. Material Safety Data Sheets contain health and safety information for your development of appropriate product handling procedures to protect your employees and customers. Mule-Hide's Material Safety Data Sheets should be read and understood by all of your supervisory personnel and employees before using Mule-Hide products in your facilities.

### **ADDITIONAL INFORMATION**

The information given on this PDS is subject to change without notice. Always check the Mule-Hide website at [www.mulehide.com](http://www.mulehide.com) for the latest information, changes and updates or contact Mule-Hide Products Company at 800-786-1492.

### **DISCLAIMER**

The statements provided concerning the material shown are intended as a guide for material usage and are believed to be true and accurate at the time of printing. No statement made by anyone may supersede this information, except when done in writing by Mule-Hide Products Co., Inc. Since the manner of use is beyond our control, Mule-Hide does not authorize anyone to make any warranty of merchantability or fitness for any particular purpose or any other warranty, guarantee or representation, expressed or implied, concerning this material. This product may be eligible for a Mule-Hide warranty, please check the Mule-Hide website at [www.mulehide.com](http://www.mulehide.com) or contact Mule-Hide directly at 800-786-1492 for details. Buyer and user accept the product under these conditions and assume the risk of any failure, any injury person or property (including that of the user), loss or liability resulting from the handling, storage or use of the product whether or not it is handled, stored or used in accordance with the directions or specifications. Mule-Hide must be notified in writing of any claims and be given the opportunity to inspect the alleged failure before repairs are made.



# Product Data Sheet

## MULE-HIDE UNCURED EPDM FLASHING TAPE

### PRODUCT DESCRIPTION

Mule-Hide Uncured EPDM Flashing Tape is an uncured EPDM flashing membrane laminated to cured butyl rubber tape and rolled onto a release liner.

### BASIC USES

Mule-Hide Uncured EPDM Flashing Tape was specifically developed for use with EPDM single-ply membrane roofing systems. Mule-Hide's flashing tapes may be used in conjunction with the Mule-Hide Tape Primer to flash inside and outside corners, pipes, pitch pockets or other penetrations that require the flashing to be molded or conform to an irregular shape. Mule-Hide's Uncured EPDM Flashing Tapes are **not permitted** for use in flashing gravel stops, drip aprons or stripping seams or batten bars.

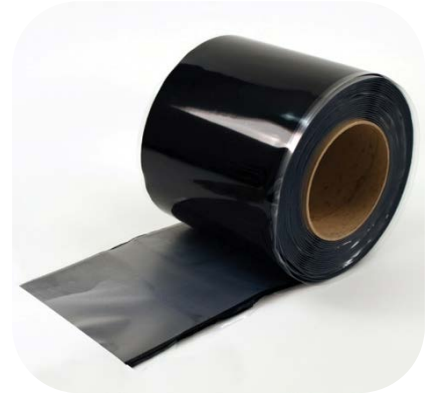

### TYPICAL PHYSICAL PROPERTIES

Typical Properties and Characteristics	
Base Polymer	Membrane - EPDM Adhesive - Synthetic Rubber
Color	Black
Ozone Resistance 100 pphm Ozone in air 168 hours @ 104°F @ 50% strain	No cracks
Nominal Thickness	90 mil (2.29 mm)
Brittleness Temperature	-49°F (-45°C)
Nominal Width 6" 9" 12"	Membrane 6" (152 mm) - Adhesive 6 <sup>3</sup> / <sub>16</sub> " (157 mm) Membrane 9" (225 mm) - Adhesive 9 <sup>3</sup> / <sub>16</sub> " (230 mm) Membrane 12" (305 mm) - Adhesive 12 <sup>3</sup> / <sub>16</sub> " (310 mm)
Shelf Life	9 months when stored between 60°F and 80°F
Typical Values: Based on material tested in our laboratories but variable from sample to sample. Typical values should not be construed as a guaranteed analysis of any specific lot or as specification items. Mule-Hide Uncured EPDM Flashing Tape meets or exceeds the minimum requirements of ASTM D4811 for a Type 1 (EPDM), Class V (cures on the roof) flashing material	

### BENEFITS & SUPPLEMENTAL STATEMENTS

- Ideal for flashing irregular pipes, penetrations and other details
- Adaptable to irregular shapes and surfaces
- Self-curing membrane
- Ease of use results in labor and cost savings in field applications

### PACKAGING

Typical Packaging			
Width	Length	Unit	Weight
6"	100 lf. (30 m)	2 per case	60 pounds (27.2 kg)
6"	25 lf. (12.5 m)	8 per case	58 pounds (26.3 kg)
9"	50 lf. (15 m)	1 per case	23 pounds (10.4 kg)
12"	50 lf. (15 m)	1 per case	30 pounds (13.6 kg)

# Product Data Sheet

MULE-HIDE UNCURED EPDM FLASHING TAPE

---

## **INSTALLATION INSTRUCTIONS**

1. The entire EPDM membrane surface where the Uncured EPDM Flashing Tape will be applied must be cleaned and primed. Neither the splice adhesive nor the Uncured EPDM Flashing Tape will adhere to dusted/dirty surfaces. Remove any dirt or dust by wiping with a clean rag. If there is a heavy layer of dirt present, clean the splice area thoroughly with Weathered Membrane Cleaner. Any residual dust/dirt will be detrimental to the bond strength of the Uncured EPDM Flashing Tape or Splice Adhesive. See Product Data Sheet for Tape Primer for installation instructions.
2. Install Uncured EPDM Flashing Tape immediately after primer flashes off to minimize potential dust contamination and promote adhesion in colder weather.
3. Position the Uncured EPDM Flashing Tape over the area to be covered and press down the exposed tape portion using firm, even hand pressure across the entire area. Continue this process until the full area to be flashed is completed.
4. Immediately roll the Uncured EPDM Flashing Tape with a 2" (50 mm) wide roller, using positive pressure. Roll across the flashing edge, not parallel to it.
5. Mule-Hide Uncured EPDM Flashing Tape is used to flash many different roofing system structures and penetrations. The specific method of applying the flashing for each individual situation is different. The appropriate Carlisle Specification and/or detail must be consulted prior to application. Review Mule-Hide Specifications and details for specific application instructions.

## **STORAGE & HANDLING**

- Prolonged jobsite storage temperatures in excess of 90°F (32°C) will shorten product shelf life. In warm, sunny weather, keep Uncured Flashing Tape rolls in original box in a shaded area until ready to use.
- Storage and use of EPDM Uncured Flashing Tape at temperatures below 40°F (4°C) will result in a loss of tape tack and, in extreme cases, will result in no bond to the substrate. Overnight storage must be available to keep the temperature of the EPDM Uncured Flashing Tape at a minimum of 60°F (15°C). Jobsite storage must be provided to maintain a minimum tape temperature of 40°F (4°C).
- Uncured Flashing Tape must be stored in a dry area.
- Shelf life is 9 months when properly stored between 60°F and 80°F. Stock should be rotated.

## **PRECAUTIONS**

- Avoid prolonged contact with skin. In case of contact with skin, thoroughly wash affected area with soap and water.
- Due to solvent flash-off, condensation may occur on freshly applied primer when the ambient temperature is near the dew point. If condensation develops, the application of primer must be discontinued as proper adhesion will not be achieved.
- Allow the primer surface to dry and apply a thin freshener coat of primer to the previously coated surface and apply Uncured Flashing Tape when conditions allow.
- Do not allow waste products (petroleum, grease, oil, solvents, vegetable or mineral oil, animal fats, etc.) or direct steam venting to come in contact with the EPDM Uncured Flashing Tape.
- KEEP OUT OF REACH OF CHILDREN

## **PROTECTION & SAFETY**

Mule-Hide maintains Safety Data Sheets on all of its non-exempt products. Safety Data Sheets contain health and safety information for your development of appropriate product handling procedures to protect your employees and customers. Mule-Hide's Safety Data Sheets should be read and understood by all of your supervisory personnel and employees before using Mule-Hide products in your facilities.

## **ADDITIONAL INFORMATION**

The information given on this PDS is subject to change without notice. Always check the Mule-Hide website at [www.mulehide.com](http://www.mulehide.com) for the latest information, changes and updates or contact Mule-Hide Products Company at 800-786-1492.



# Product Data Sheet

MULE-HIDE UNCURED EPDM FLASHING TAPE

---

## **DISCLAIMER**

The statements provided concerning the material shown are intended as a guide for material usage and are believed to be true and accurate at the time of printing. No statement made by anyone may supersede this information, except when done in writing by Mule-Hide Products Co., Inc. Since the manner of use is beyond our control, Mule-Hide does not authorize anyone to make any warranty of merchantability or fitness for any particular purpose or any other warranty, guarantee or representation, expressed or implied, concerning this material. This product may be eligible for a Mule-Hide warranty, please check the Mule-Hide website at [www.mulehide.com](http://www.mulehide.com) or contact Mule-Hide directly at 800-786-1492 for details. Buyer and user accept the product under these conditions and assume the risk of any failure, any injury person or property (including that of the user), loss or liability resulting from the handling, storage or use of the product whether or not it is handled, stored or used in accordance with the directions or specifications. Mule-Hide must be notified in writing of any claims and be given the opportunity to inspect the alleged failure before repairs are made.



## Product Data Sheet

# MULE-HIDE TAPE PRIMER

### PRODUCT DESCRIPTION

Mule-Hide Tape Primer is a solvent-based product designed for one-step cleaning and priming of EPDM surfaces to be bonded with In-Seam Tapes, Uncured Flashing Tapes, Cured Cover Tapes, and Pre-Taped membranes.

### BASIC USES

A product designed for priming of EPDM surfaces prior to the application of Taped Products. Also used with EPDM for application of In-Seam Tapes.

### TYPICAL PHYSICAL PROPERTIES\*

Physical Properties*	
Base Material	Synthetic Rubber
Solids	18%
Flash Point	40°F (4.4°C)
Shelf Life	12 months
Average Weight	7.3 lbs./gallon (0.9 kg/liter)
*General properties. Typical properties and characteristics are based on samples tested and are not guaranteed for all samples of this product. This data and information is intended as a guide and does not reflect the specification or specification range for any particular property of this product.	



### COLOR

Olive Drab to Dark Gray

### PACKAGING

(6) 1 gallon (3.8 liter) cans per carton, or (8) 1 quart (0.95 liter) screw top cans per carton

### BENEFITS & SUPPLEMENTAL STATEMENTS

Promotes excellent adhesion with Tape Products  
One step cleaner and primer when used on pre-cleaned sheets

### COVERAGE RATES

Approximately 250 square feet / gallon on standard EPDM (dusted).  
Coverage rates as high as 450 square feet on Pre-Cleaned Membrane or standard membrane that is first cleaned with Weathered Membrane Cleaner.

### LEED INFORMATION

LEED® Information	
Pre-consumer Recycled Content	0%
Post-consumer Recycled Content	0%
Manufacturing Location	Carlisle, PA
VOC Content	714 g/L



# MULE-HIDE TAPE PRIMER

## INSTALLATION TEMPERATURE

If primer is stored at temperatures less than 60° F, restore to room temperature (~70° F) before using.

## INSTALLATION INSTRUCTIONS

### Surface Preparation

1. Remove all foreign material by brooming or washing with water. If membrane is very dirty, scrubbing with Weathered Membrane Cleaner may be necessary. This process is essential on membrane that has been exposed for a number of weeks.

Note: Permeation resistant gloves (that meet ANSI/ISEA 105-2005) are required for hand protection when cleaners or primers are being used.

### Application

1. Thoroughly stir primer until all settled materials are blended into the solution.
2. Dusted Membrane:

Option 1: Apply the primer with Scotch-Brite® pads or clean rags. Scrub the area of the membrane (where the Pre-Taped Sheet, Taped Product or Splicing Cement is to be applied) in a circular motion to achieve a thin, even coating on the membrane. The properly cleaned/primed area will be uniform in color without streaks and free of globs or puddles.

Option 2: Clean the surface of the membrane to be primed with clean rags and Weathered Membrane Cleaner. Change rags often to ensure mica dust is removed. Roller apply the primer to the membrane with a short nap-length paint roller. The coated area must be free of globs or puddles.

3. Pre-Cleaned Membrane: Roller apply the primer to the membrane with a short nap-length paint roller. The coated area must be free of globs or puddles.
4. Note: The use of excessive amounts of Mule-Hide Tape Primer will not significantly enhance the adhesion of the Pre-Taped or Taped Product to the EPDM membrane. Use only the amount necessary to obtain 100% coverage of the area where the tape or adhesive will be applied.
5. Allow the Mule-Hide Tape Primer to dry until it does not transfer to a dry finger touch. Prompt installation of the In-Seam Tape or Taped Product as soon as the primer flashes off minimizes potential dust contamination and promotes adhesion in colder weather.
6. Complete the splice as specified in Mule-Hide's Specifications and Details.

\*\* REVIEW CURRENT MULE-HIDE SPECIFICATIONS AND DETAILS FOR SPECIFIC APPLICATION REQUIREMENTS.

### Precautions

1. This product is FLAMMABLE. Precautions must be taken to keep the primer away from heat, flame and sparks during storage and use.



## Product Data Sheet

# MULE-HIDE TAPE PRIMER

2. Avoid contact with eyes and skin.
3. Avoid breathing vapors. Keep container closed when not in use. Use with adequate ventilation. If inhaled, remove to fresh air. If not breathing, perform artificial respiration. If breathing is difficult, give oxygen. Call a physician immediately. During application, efforts must be made to prevent fumes from entering the building via air ventilation ducts. Do not place open containers or mix adhesive near fresh air intake units. When possible, shut down or seal off the closest units.
4. If swallowed, DO NOT INDUCE VOMITING. Call a physician immediately.
5. Chemically-resistant gloves must be worn with Mule-Hide Tape Primer to protect hands from staining and irritating ingredients.
6. Thoroughly stir this product until all settled pigment is blended into the solution. Solids suspended in Mule-Hide Tape Primer tend to settle. Use Mule-Hide Tape Primer full strength. Do not thin. Thinning will affect performance.
7. Mule-Hide Tape Primer may cause staining of White-on-Black membrane and other non-black surfaces.
8. Due to solvent flash-off, condensation may form on freshly applied Mule-Hide Tape Primer when the ambient temperature is near the dew point. If condensation develops, the application of primer must be discontinued (proper adhesion will not be obtained). Allow the surface to dry and apply a thin freshener coat of primer to the previously coated surface when conditions allow.

REVIEW THE MULE-HIDE EPDM PRIMER MATERIAL SAFETY DATA SHEET FOR COMPLETE SAFETY INFORMATION PRIOR TO USE.

**KEEP OUT OF REACH OF CHILDREN.**

### **STORAGE & HANDLING**

Job site storage temperatures in excess of 90°F (32°C) may affect product shelf life. Should the primer be stored at temperatures lower than 60°F (15°C), restore to room temperature prior to use.

Keep can tightly closed when not in use and protect from moisture contamination. Once exposed to moisture in the air, Mule-Hide Tape Primer begins to cure and may gel within a few days. A gasket of membrane or sealant can be used to create a positive seal.

### **PROTECTION & SAFETY**

Mule-Hide maintains Material Safety Data Sheets on all of its products. Material Safety Data Sheets contain health and safety information for your development of appropriate product handling procedures to protect your employees and customers. Mule-Hide's Material Safety Data Sheets should be read and understood by all of your supervisory personnel and employees before using Mule-Hide products in your facilities.



## Product Data Sheet

# MULE-HIDE TAPE PRIMER

### **ADDITIONAL INFORMATION**

The information given on this PDS is subject to change without notice. Always check the Mule-Hide website at [www.mulehide.com](http://www.mulehide.com) for the latest information, changes and updates or contact Mule-Hide Products Company at 800-786-1492.

### **DISCLAIMER**

The statements provided concerning the material shown are intended as a guide for material usage and are believed to be true and accurate at the time of printing. No statement made by anyone may supersede this information, except when done in writing by Mule-Hide Products Co., Inc. Since the manner of use is beyond our control, Mule-Hide does not authorize anyone to make any warranty of merchantability or fitness for any particular purpose or any other warranty, guarantee or representation, expressed or implied, concerning this material. This product may be eligible for a Mule-Hide warranty, please check the Mule-Hide website at [www.mulehide.com](http://www.mulehide.com) or contact Mule-Hide directly at 800-786-1492 for details. Buyer and user accept the product under these conditions and assume the risk of any failure, any injury person or property (including that of the user), loss or liability resulting from the handling, storage or use of the product whether or not it is handled, stored or used in accordance with the directions or specifications. Mule-Hide must be notified in writing of any claims and be given the opportunity to inspect the alleged failure before repairs are made.



# Product Data Sheet

## LOW VOC PRIMER

### PRODUCT DESCRIPTION

Low VOC Primer is a solvent-based product designed for one-step cleaning and priming of EPDM and TPO surfaces to be bonded with In-Seam Tapes, Uncured Flashing Tapes, Cured Cover Tapes, and Pre-Taped membranes. It is a Low VOC product that is ideal for use where environmental concerns are an issue.

### BASIC USES

A Low VOC product designed for one-step cleaning and priming of EPDM and TPO surfaces prior to the application of In-Seam Tapes and other Taped Products.



### TYPICAL PHYSICAL PROPERTIES\*

Typical Properties and Characteristics	
Base Material	Synthetic Rubber
Color	Olive Drab
Solids	9%
Flash Point	40°F (4.4°C)
Shelf Life	9 months
Average Weight	9.55 lbs./gallon (1.14 kg/liter)

Leed Information	
Pre-consumer Recycled Content	0%
Post-consumer Recycled Content	0%
Manufacturing Location	Carlisle, PA
VOC Content	<250 g/l

\*General properties. Typical properties and characteristics are based on samples tested and are not guaranteed for all samples of this product. This data and information is intended as a guide and does not reflect the specification or specification range for any particular property of this product.

### PACKAGING

(6) 1 gallon (3.8 liter) cans per carton

### BENEFITS & SUPPLEMENTAL STATEMENTS

- Promotes excellent long term adhesion with Tape Products
- One step cleaner and primer for EPDM and TPO membranes
- VOC less than 250 g/l

### COVERAGE RATES

Approximately 250 square feet / gallon with Dusted Sheet  
Approximately 700 square feet / gallon with TPO

### INSTALLATION TEMPERATURE

If primer is store at temperatures less than 60° F, restore to room temperature (~70° F) before using.

### MIXING

**Mixing is not recommended, even when settling has occurred.** The Low-VOC Primer contains a non-partitioning agent that may settle to the bottom of the can. Do not attempt to break up or stir back into the primer.

# Product Data Sheet

Low VOC PRIMER

---

## INSTALLATION INSTRUCTIONS

### Surface Preparation

1. Remove all foreign material by brooming or washing with water. If membrane is very dirty, scrubbing with Weathered Membrane Cleaner may be necessary. This process is essential on membrane that has been exposed for a number of weeks.

Note: Permeation resistant gloves (that meet ANSI/ISEA 105-2005) are required for hand protection when cleaners or primers are being used.

### Application

1. **Mixing is not recommended, even when settling has occurred.**
2. Apply the primer with Scotch-Brite® pads or clean rags. Scrub the area of the membrane (where the Pre-Taped Sheet, Taped Product or Splicing Cement is to be applied) in a circular motion to achieve a thin, even coating on the membrane. The properly cleaned/primed area will be uniform in color without streaks and free of globs or puddles.
3. Note: The use of excessive amounts of Low VOC Primer will not significantly enhance the adhesion of the Pre-Taped or Taped Product to the EPDM or TPO membrane. Use only the amount necessary to obtain 100% coverage of the area where the tape or adhesive will be applied.
4. Allow the Low VOC Primer to dry until it does not transfer to a dry finger touch. Prompt installation of the In-Seam Tape or Taped Product as soon as the primer flashes off minimizes potential dust contamination and promotes adhesion in colder weather.
5. Complete the splice as specified in Mule-Hide's Specifications and Details.

*Review current Mule-Hide specifications and details for additional information.*

### Precautions

1. Do not allow primer to over dry or lose tack.
2. Install taped products immediately after primer flashes off and while primer is still tacky.
3. This product is **FLAMMABLE**. Precautions must be taken to keep the primer away from heat, flame and sparks during storage and use.
4. Avoid contact with eyes and skin.
5. Avoid breathing vapors. Keep container closed when not in use. Use with adequate ventilation. If inhaled, remove to fresh air. If not breathing, perform artificial respiration. If breathing is difficult, give oxygen. Call a physician immediately. During application, efforts must be made to prevent fumes from entering the building via air ventilation ducts. Do not place open containers or mix adhesive near fresh air intake units. When possible, shut down or seal off the closest units.
6. If swallowed, **DO NOT INDUCE VOMITING**. Call a physician immediately.
7. Chemically-resistant gloves must be worn with Low VOC Primer to protect hands from staining and irritating ingredients.
8. Solids suspended in Low VOC Primer tend to settle and **DO NOT NEED TO BE REMIXED**. Stirring is not required. Use Low VOC Primer full strength. Do not thin. Thinning will affect performance.
7. Low VOC Primer is not white in color and may cause staining of White-on-Black membrane and other non-black surfaces. For appearance, care should be taken to limit the amount of primer exposed beyond the splice area.
8. Due to solvent flash-off, condensation may form on freshly applied Low VOC Primer when the ambient temperature is near the dew point. If condensation develops, the application of primer must be discontinued (proper adhesion will not be obtained). Allow the surface to dry and apply a thin freshener coat of primer to the previously coated surface when conditions allow.

REVIEW THE LOW VOC PRIMER MATERIAL SAFETY DATA SHEET FOR COMPLETE SAFETY INFORMATION PRIOR TO USE. **KEEP OUT OF REACH OF CHILDREN.**

# Product Data Sheet

Low VOC PRIMER

---

## **STORAGE & HANDLING**

Job site storage temperatures in excess of 90°F (32°C) may affect product shelf life. Should the primer be stored at temperatures lower than 60°F (15°C), restore to room temperature prior to use.

Keep can tightly closed when not in use and protect from moisture contamination. Once exposed to moisture in the air, Low VOC Primer begins to cure and may gel within a few days. A gasket of membrane or sealant can be used to create a positive seal.

## **PROTECTION & SAFETY**

Mule-Hide maintains Safety Data Sheets on all of its non-exempt products. Safety Data Sheets contain health and safety information for your development of appropriate product handling procedures to protect your employees and customers. Mule-Hide's Safety Data Sheets should be read and understood by all of your supervisory personnel and employees before using Mule-Hide products in your facilities.

## **ADDITIONAL INFORMATION**

The information given on this PDS is subject to change without notice. Always check the Mule-Hide website at [www.mulehide.com](http://www.mulehide.com) for the latest information, changes and updates or contact Mule-Hide Products Company at 800-786-1492.

## **DISCLAIMER**

The statements provided concerning the material shown are intended as a guide for material usage and are believed to be true and accurate at the time of printing. No statement made by anyone may supersede this information, except when done in writing by Mule-Hide Products Co., Inc. Since the manner of use is beyond our control, Mule-Hide does not authorize anyone to make any warranty of merchantability or fitness for any particular purpose or any other warranty, guarantee or representation, expressed or implied, concerning this material. Buyer and user accept the product under these conditions and assume the risk of any failure, any injury person or property (including that of the user), loss or liability resulting from the handling, storage or use of the product whether or not it is handled, stored or used in accordance with the directions or specifications. Mule-Hide must be notified in writing of any claims and be given the opportunity to inspect the alleged failure before repairs are made.





# MULE-HIDE CURED EPDM COVER TAPE

## PRODUCT DESCRIPTION

Rev. Mar 2021

Mule-Hide Cured Cover Tape is a nominal 60-mil, cured EPDM membrane strip laminated to nominal 30-mil cured butyl rubber tape and rolled onto a release liner, for a total nominal thickness of 90-mil.

## BASIC USES

Mule-Hide Cured Cover Tape was specifically developed for use with EPDM single-ply membrane roofing systems. Mule-Hide's Cured Cover Tapes may be used in conjunction with the Mule-Hide Tape Primer to strip gravel stops, drip aprons, seams or batten bars, and can be used to make repairs to cut membrane.



## SPECIFICATIONS

Typical Physical Properties*	
Base Membrane	EPDM
Adhesive	Synthetic Rubber
Color	Black
Solids	100%
Tensile Strength	1650 psi (11.3Mpa) minimum
Elongation	1480% minimum
Brittleness Temperature	Below -67°F (-55 °C)
Tear Resistance	150 lbs/in (35 nK/m)
Ozone Resistance Condition after exposure to 100 pphm Ozone in air for 168 hrs @ 104oF (40oC) (Specimen under 50% strain)	No Cracks
Nominal Thickness	88-mil (2.24 mm)
Nominal Width	Membrane - Adhesive 6" (150 mm) – 6 3/16" (155 mm) 9" (225 mm) – 9 3/16" (230 mm) 12" (300 mm) – 12 3/16" (305 mm)
Shelf Life	1 year when properly stored
*Typical properties and characteristics are based on samples tested and are not guaranteed for all samples of this product. This data and information is intended as a guide and does not reflect the specification or specification range for any particular property of this product.	

## PACKAGING

Roll Size	Net weight per roll	Packaging
6" x 100 feet	30 lbs (14 kg)	2 rolls per carton
9" x 100 feet	45 lbs (21 kg)	1 roll per carton
12" x 50 feet	30 lbs (14 kg)	1 roll per carton

## BENEFITS & SUPPLEMENTAL STATEMENTS

- Contains no solvent
- Labor savings up to 50%
- Superior tack and green strength
- Superior peel and shear strengths
- Ease of installation
- Reduces application problems of adhesives
- Strength improves with age

# MULE-HIDE CURED EPDM COVER TAPE

---

## **INSTALLATION INSTRUCTIONS**

1. The entire EPDM membrane surface where the Cured EPDM Cover Tape will be applied must be cleaned and primed. Neither the splice adhesive nor the Cured EPDM Cover Tape will adhere to dusted/dirty surfaces. Remove any dirt or dust by wiping with a clean rag. If there is a heavy layer of dirt present, clean the splice area thoroughly with Weathered Membrane Cleaner. Any residual dust/dirt will be detrimental to the bond strength of the Cured EPDM Cover Tape or Splice Adhesive. See Product Data Sheet for Tape Primer for installation instructions.
2. Install Cured EPDM Cover Tape immediately after primer flashes off to minimize potential dust contamination and promote adhesion in colder weather.
3. Position the Cured EPDM Cover Tape over the area to be covered and press down the exposed tape portion using firm, even hand pressure across the entire area. Continue this process until the full area to be flashed is completed.
4. Immediately roll the Cured EPDM Cover Tape with a 2" (50 mm) wide roller, using positive pressure. Roll across the flashing edge, not parallel to it.
5. Mule-Hide Cured EPDM Cover Tape is used to flash many different roofing system structures and penetrations. The specific method of applying the flashing for each individual situation is different.

Review Mule-Hide Specifications and details for specific application instructions.

## **STORAGE & HANDLING**

- Prolonged jobsite storage temperatures in excess of 90°F (32°C) will shorten product shelf life. In warm, sunny weather, keep Cured Cover Tape rolls in original box in a shaded area until ready to use.
- Storage and use of EPDM Cured Cover Tape at temperatures below 40°F (4°C) will result in a loss of tape tack and, in extreme cases, will result in no bond to the substrate. Overnight storage must be available to keep the temperature of the EPDM Cured Cover Tape at a minimum of 60°F (15°C). Jobsite storage must be provided to maintain a minimum tape temperature of 40°F (4°C).
- Cured Cover Tape must be stored in a dry area.
- Shelf life is 1 year when properly stored between 60°F and 80°F. Stock should be rotated.

## **PRECAUTIONS**

- Avoid prolonged contact with skin. In case of contact with skin, thoroughly wash affected area with soap and water.
- Due to solvent flash-off, condensation may occur on freshly applied primer when the ambient temperature is near the dew point. If condensation develops, the application of primer must be discontinued as proper adhesion will not be achieved.
- Allow the primer surface to dry and apply a thin freshener coat of primer to the previously coated surface and apply Cured Cover Tape when conditions allow.
- Cured Cover Tape is cured and cannot be used for flashing corners, pipes or T-Joint Covers.
- Do not allow waste products (petroleum, grease, oil, solvents, vegetable or mineral oil, animal fats, etc.) or direct steam venting to come in contact with the EPDM Cured Cover Tape.
- KEEP OUT OF REACH OF CHILDREN

## **LEED INFORMATION**

LEED® Information	
Pre-consumer Recycled Content	2%
Post-consumer Recycled Content	0%
Manufacturing Location	Greenville, IL

## **PROTECTION & SAFETY**

Mule-Hide maintains Safety Data Sheets on all of its non-exempt products. Safety Data Sheets contain health and safety information for your development of appropriate product handling procedures to protect your

# MULE-HIDE CURED EPDM COVER TAPE

---

employees and customers. Mule-Hide's Safety Data Sheets should be read and understood by all of your supervisory personnel and employees before using Mule-Hide products in your facilities.

## **ADDITIONAL INFORMATION**

The information given on this PDS is subject to change without notice. Always check the Mule-Hide website at [www.mulehide.com](http://www.mulehide.com) for the latest information, changes and updates or contact Mule-Hide Products Company at 800-786-1492.

## **DISCLAIMER**

The statements provided concerning the material shown are intended as a guide for material usage and are believed to be true and accurate at the time of printing. No statement made by anyone may supersede this information, except when done in writing by Mule-Hide Products Co., Inc. Since the manner of use is beyond our control, Mule-Hide does not authorize anyone to make any warranty of merchantability or fitness for any particular purpose or any other warranty, guarantee or representation, expressed or implied, concerning this material. This product may be eligible for a Mule-Hide warranty, please check the Mule-Hide website at [www.mulehide.com](http://www.mulehide.com) or contact Mule-Hide directly at 800-786-1492 for details. Buyer and user accept the product under these conditions and assume the risk of any failure, any injury person or property (including that of the user), loss or liability resulting from the handling, storage or use of the product whether or not it is handled, stored or used in accordance with the directions or specifications. Mule-Hide must be notified in writing of any claims and be given the opportunity to inspect the alleged failure before repairs are made.



# Product Data Sheet

## MULE-HIDE REINFORCED EPDM MEMBRANE STRIPS (RMS)

### PRODUCT DESCRIPTION

Mule-Hide Reinforced EPDM Membrane Strips (RMS) are available in 6" and 9" widths. The 6" RMS is typically used to secure the field membrane at the base of parapets and curbs, eliminating the need for a field seam. The 9" strip is used in the field of the roof for membrane securement in mechanically attached systems.

### BASIC USES

Mule-Hide 6" RMS strips are used in conjunction with Mule-Hide's 2.4" seam plates and Mule-Hide HDP fasteners as securement of the EPDM membranes at the base of parapet walls and curbs. The Mule-Hide 6" RMS strips are installed beneath the EPDM field sheet and used as an alternate method to using the Mule-Hide All Purpose Bar.



The 6" RMS strip may be installed either horizontally or vertically. The 6" RMS has a 3" wide In-seam tape pre-applied to one edge. The EPDM field sheet is then seamed to the RMS. When using the RMS, Tape Primer must be used to prime the EPDM membrane.

Mule-Hide's 9" wide RMS strips have two rows of 3" wide In-Seam tape applied to both edges, and is used horizontally for membrane attachment in mechanically attached systems. The EPDM membrane is primed with Tape Primer.

### TYPICAL PHYSICAL PROPERTIES

Typical Properties and Characteristics*		
Property	6" RMS	9" RMS
Base	Membrane – Reinforced EPDM Adhesive – EPDM	Membrane – Reinforced EPDM Adhesive – EPDM
Roll Size	6" x 100' (152 mm x 30.5m)	9" x 100' (228 mm x 30.5m)
Thickness – EPDM Tape	45-mil (1.14 mm) 30-mil (0.76 mm)	45-mil (1.14 mm) 30-mil (0.76 mm)
Packaging	200 LF/ctn (61 m) 2 rolls	100 LF/ctn (30.5 m) 1 roll
Net Wt per Carton	38 lbs (17.2 kg)	33 lbs (15 kg)
Shelf Life	1 year	1 year
*Typical properties and characteristics are based on samples tested and are not guaranteed for all samples of this product. This data and information is intended as a guide and does not reflect the specification or specification range for any particular property of this product.		

### BENEFITS & SUPPLEMENTAL STATEMENTS

- Ideal for perimeter membrane securement
- Ideal for membrane securement at base of projections
- Can eliminate field seam at roof perimeter

### INSTALLATION INSTRUCTIONS

1. Unroll and position RMS strip
  - a. 6" RMS– Position 6" RMS horizontally or vertically in the angle change with the pre-applied tape facing upward and on the horizontal surface. Tape is to be on 'roof' side of RMS.
  - b. 9" RMS – Position 9" RMS in the field of the roof with tape side up.

# Product Data Sheet

## MULE-HIDE REINFORCED EPDM MEMBRANE STRIPS (RMS)

---

### **INSTALLATION INSTRUCTIONS (continued)**

2. Position 2.4" Seam Plates spaced either 6" (150 mm) or 12" (305 mm) on center and secure with a Mule-Hide HDP fastener. Do not fasten plates over top of release liner, as this will cause liner to tear when removed.
  - a. 6" RMS – Place 2.4" Seam Plates 1/8" to 3/4" from edge of 6" RMS
  - b. 9" RMS – Place 2.4" Seam Plates along center line portion of 9" RMS
3. The entire EPDM membrane surface where the RMS will be applied must be cleaned and primed. In-Seam Tape will not adhere to dusted/dirty surfaces. Remove any dirt or dust by wiping with a clean rag. If there is a heavy layer of dirt present, clean the splice area thoroughly with Weathered Membrane Cleaner. Any residual dust/dirt will be detrimental to the bond strength of the In-Seam Tape. See Product Data Sheet for Tape Primer for installation instructions.
4. RMS Preparation
  - a. Remove the release liner(s) from the In-Seam Tape strip(s), pulling it parallel to deck. (do not apply tape primer to In-Seam Tape)
5. Install RMS Strip immediately after primer flashes off to minimize potential dust contamination and promote adhesion in colder weather.
6. Roll the field membrane onto the exposed adhesive and apply hand pressure to the splice area.
7. For 6" RMS installation
  - a. Pull the field membrane back to expose the un-adhered portion of the RMS. Apply Mule-Hide Bonding Adhesive to the deck membrane, exposed RMS and parapet wall or curb.
  - b. Once adhesive has dried, roll field membrane into the angle change and crease. Roll membrane up the vertical surface and broom to achieve 100% contact.
8. Roll the entire width of the RMS with a 2" (51 mm) wide roller using positive pressure.
9. Review Mule-Hide Specifications and details for specific application instructions.

### **PRECAUTIONS**

- Avoid prolonged contact with skin. In case of contact with skin, thoroughly wash affected area with soap and water.
- Prolonged jobsite storage temperatures in excess of 90°F (32°C) will shorten product shelf life.
- In warm, sunny weather, keep In-Seam Tape rolls in original box in a shaded area until ready to use.
- Storage and use of RMS at temperatures below 40°F (4°C) will result in a loss of tape tack and, in extreme cases, will result in no bond to the substrate. Overnight storage must be available to keep the temperature of the RMS at a minimum of 60°F (15°C). Hot boxes for jobsite storage must be provided to maintain a minimum tape temperature of 40°F (4°C).
- RMS must be stored in a dry area.
- Due to solvent flash-off, condensation may occur on freshly applied primer when the ambient temperature is near the dew point. If condensation develops, the application of primer and In-Seam Tape must be discontinued as proper adhesion will not be achieved.
- Allow the primer surface to dry and apply a thin freshener coat of primer to the previously coated surface and apply In-Seam Tape when conditions allow.
- Mule-Hide 2.4" Seam Plates and Mule-Hide HDP fasteners must be used when installing RMS.
- RMS is intended to be used with BLACK EPDM membranes. Use with White-on-Black EPDM membranes will result in discoloration of the membrane over time.
- KEEP OUT OF REACH OF CHILDREN

### **PROTECTION & SAFETY**

Mule-Hide maintains Safety Data Sheets on all of its non-exempt products. Safety Data Sheets contain health and safety information for your development of appropriate product handling procedures to protect your employees and customers. Mule-Hide's Safety Data Sheets should be read and understood by all of your supervisory personnel and employees before using Mule-Hide products in your facilities.

# Product Data Sheet

MULE-HIDE REINFORCED EPDM MEMBRANE STRIPS (RMS)

---

## **ADDITIONAL INFORMATION**

The information given on this PDS is subject to change without notice. Always check the Mule-Hide website at [www.mulehide.com](http://www.mulehide.com) for the latest information, changes and updates or contact Mule-Hide Products Company at 800-786-1492.

## **DISCLAIMER**

The statements provided concerning the material shown are intended as a guide for material usage and are believed to be true and accurate at the time of printing. No statement made by anyone may supersede this information, except when done in writing by Mule-Hide Products Co., Inc. Since the manner of use is beyond our control, Mule-Hide does not authorize anyone to make any warranty of merchantability or fitness for any particular purpose or any other warranty, guarantee or representation, expressed or implied, concerning this material. Buyer and user accept the product under these conditions and assume the risk of any failure, any injury person or property (including that of the user), loss or liability resulting from the handling, storage or use of the product whether or not it is handled, stored or used in accordance with the directions or specifications. Mule-Hide must be notified in writing of any claims and be given the opportunity to inspect the alleged failure before repairs are made.



# Product Data Sheet

## MULE-HIDE PRE-CUT EPDM T-JOINT PATCHES

### PRODUCT DESCRIPTION

Mule-Hide EPDM T-Joint Patches consist of 40 mil (1mm) thick uncured EPDM flashing material laminated to cured butyl rubber tape and rolled onto a poly release liner for a total thickness of 70 mils (1.75 mm).

### BASIC USES

Mule-Hide EPDM T-Joint Patches are used to seal field splice joints or a horizontal to vertical transitions of field seams on Mule-Hide EPDM roofing systems.



### SPECIFICATIONS

Typical Properties*	
Sizes:	6" x 6" (150 mm x 150 mm) 12" x 12" (300 mm x 300 mm)
Packaging:	20 per carton
Weight:	3 lbs / carton (1.35 kg) for 6" x 6" 10 lbs / carton (4.5 kg) for 12" x 12"
Color:	Black
Shelf Life:	Nine (9) months when stored between 60°F and 80°F (15°C and 27°C)
*Typical properties and characteristics are based on samples tested and are not guaranteed for all samples of this product. This data and information is intended as a guide and does not reflect the specification range for any particular property of this product.	

LEED Information	
Pre-consumer Recycled Content	2%
Post-consumer Recycled Content	0%
Manufacturing Location	Greenville, IL
Solar Reflectance Index (SRI)	N/A

### BENEFITS & SUPPLEMENTAL STATEMENTS

- EPDM T-Joint Patches increase installation speed by eliminating cutting time eliminating
- Pre-applied adhesive eliminates need to apply splice adhesive
- Cleaner appearance as all patches are cut to same size

### INSTALLATION INSTRUCTIONS

1. The entire EPDM membrane surface where the EPDM T-Joint Patches will be applied must be cleaned and primed. Neither the splice adhesive nor the EPDM T-Joint Patches will adhere to dusted/dirty surfaces. Remove any dirt or dust by wiping with a clean rag. If there is a heavy layer of dirt present, clean the splice area thoroughly with Weathered Membrane Cleaner. Any residual dust/dirt will be detrimental to the bond strength of the EPDM T-Joint Patches. See Product Data Sheet for Tape Primer for installation instructions.
2. Install EPDM T-Joint Patches immediately after primer flashes off to minimize potential dust contamination and promote adhesion in colder weather.
3. Peel off one piece of the release liner and apply corner to the vertical wall. Remove the other piece of liner and work corner onto the deck from the corner out using even hand pressure across the entire area.

# Product Data Sheet

MULE-HIDE PRE-CUT EPDM T-JOINT PATCHES

---

## **INSTALLATION INSTRUCTIONS (continued)**

4. Immediately roll the Inside/Outside Corner with a 2" (50 mm) wide roller, using positive pressure.
5. Apply Lap Sealant at overlaps in PS Inside/Outside Corners or at joints in the metal edging according to the appropriate detail.

Review Mule-Hide Specifications and details for additional application instructions.

## **PRECAUTIONS**

- Avoid prolonged contact with skin. In case of contact with skin, thoroughly wash affected area with soap and water.
- Prolonged jobsite storage temperatures in excess of 90°F (32°C) will shorten product shelf life.
- In warm, sunny weather, keep EPDM T-Joint Patches in original box in a shaded area until ready to use.
- Storage and use of EPDM T-Joint Patches at temperatures below 40°F (4°C) will result in a loss of tape tack and, in extreme cases, will result in no bond to the substrate. Overnight storage must be available to keep the temperature of the EPDM T-Joint Patches at a minimum of 60°F (15°C). Hot boxes for jobsite storage must be provided to maintain a minimum tape temperature of 40°F (4°C).
- EPDM T-Joint Patches must be stored in a dry area.
- Due to solvent flash-off, condensation may occur on freshly applied primer when the ambient temperature is near the dew point. If condensation develops, the application of primer must be discontinued as proper adhesion will not be achieved.
- Allow the primer surface to dry and apply a thin freshener coat of primer to the previously coated surface and apply Uncured Flashing Tape when conditions allow.
- Do not allow waste products (petroleum, grease, oil, solvents, vegetable or mineral oil, animal fats, etc.) or direct steam venting to come in contact with the EPDM T-Joint Patches.
- KEEP OUT OF REACH OF CHILDREN

## **PROTECTION & SAFETY**

Mule-Hide maintains Safety Data Sheets on all of its non-exempt products. Safety Data Sheets contain health and safety information for your development of appropriate product handling procedures to protect your employees and customers. Mule-Hide's Safety Data Sheets should be read and understood by all of your supervisory personnel and employees before using Mule-Hide products in your facilities.

## **ADDITIONAL INFORMATION**

The information given on this PDS is subject to change without notice. Always check the Mule-Hide website at [www.mulehide.com](http://www.mulehide.com) for the latest information, changes and updates or contact Mule-Hide Products Company at 800-786-1492.

## **DISCLAIMER**

The statements provided concerning the material shown are intended as a guide for material usage and are believed to be true and accurate at the time of printing. No statement made by anyone may supersede this information, except when done in writing by Mule-Hide Products Co., Inc. Since the manner of use is beyond our control, Mule-Hide does not authorize anyone to make any warranty of merchantability or fitness for any particular purpose or any other warranty, guarantee or representation, expressed or implied, concerning this material. Buyer and user accept the product under these conditions and assume the risk of any failure, any injury person or property (including that of the user), loss or liability resulting from the handling, storage or use of the product whether or not it is handled, stored or used in accordance with the directions or specifications. Mule-Hide must be notified in writing of any claims and be given the opportunity to inspect the alleged failure before repairs are made.





# Product Data Sheet

## MULE-HIDE PRE-CUT INSIDE/OUTSIDE CORNERS

### PRODUCT DESCRIPTION

Mule-Hide Pre-Cut Inside/Outside Corners consist of .060 inch (1.5mm) thick uncured EPDM flashing material laminated to cured butyl rubber tape and rolled onto a poly release liner providing .090 mils (2.25mm) of total thickness.

### BASIC USES

Mule-Hide Pre-Cut Inside/Outside Corners are ideal for installing inside and outside corners on Mule-Hide EPDM roofing systems.



### SPECIFICATIONS

Typical Properties*	
Sizes:	7" x 9" (180 mm x 230 mm)
Packaging:	20 per carton
Weight:	5 lbs. per carton (2.25Kg)
Color:	Black
Shelf Life:	Nine (9) months when stored between 60°F and 80°F (15°C and 26°C)
*Typical properties and characteristics are based on samples tested and are not guaranteed for all samples of this product. This data and information is intended as a guide and does not reflect the specification range for any particular property of this product.	

LEED Information	
Pre-consumer Recycled Content	2%
Post-consumer Recycled Content	0%
Manufacturing Location	Greenville, IL
Solar Reflectance Index (SRI)	N/A

### BENEFITS & SUPPLEMENTAL STATEMENTS

- Pre-cut corners increase installation speed by eliminating cutting time eliminating
- Pre-applied adhesive eliminates need to apply splice adhesive
- Cleaner appearance as all corners are cut to same size

### INSTALLATION INSTRUCTIONS

1. The entire EPDM membrane surface where the Pre Cut Corners will be applied must be cleaned and primed. Neither the splice adhesive nor the Pre Cut Corners will adhere to dusted/dirty surfaces. Remove any dirt or dust by wiping with a clean rag. If there is a heavy layer of dirt present, clean the splice area thoroughly with Weathered Membrane Cleaner. Any residual dust/dirt will be detrimental to the bond strength of the Pre Cut Corners. See Product Data Sheet for Tape Primer for installation instructions.
2. Install Pre Cut Corners immediately after primer flashes off to minimize potential dust contamination and promote adhesion in colder weather.
3. Peel off one piece of the release liner and apply corner to the vertical wall. Remove the other piece of liner and work corner onto the deck from the corner out using even hand pressure across the entire area.
4. Immediately roll the Inside/Outside Corner with a 2" (50 mm) wide roller, using positive pressure.
5. Apply Lap Sealant at overlaps in PS Inside/Outside Corners or at joints in the metal edging according to the appropriate detail.

Review Mule-Hide Specifications and details for additional application instructions.

# Product Data Sheet

MULE-HIDE PRE-CUT INSIDE/OUTSIDE CORNERS

---

## **PRECAUTIONS**

- Avoid prolonged contact with skin. In case of contact with skin, thoroughly wash affected area with soap and water.
- Prolonged jobsite storage temperatures in excess of 90°F (32°C) will shorten product shelf life.
- In warm, sunny weather, keep Pre Cut Corners in original box in a shaded area until ready to use.
- Storage and use of Pre Cut Corners at temperatures below 40°F (4°C) will result in a loss of tape tack and, in extreme cases, will result in no bond to the substrate. Overnight storage must be available to keep the temperature of the Pre Cut Corners at a minimum of 60°F (15°C). Hot boxes for jobsite storage must be provided to maintain a minimum tape temperature of 40°F (4°C).
- Pre Cut Corners must be stored in a dry area.
- Due to solvent flash-off, condensation may occur on freshly applied primer when the ambient temperature is near the dew point. If condensation develops, the application of primer must be discontinued as proper adhesion will not be achieved.
- Allow the primer surface to dry and apply a thin freshener coat of primer to the previously coated surface and apply Uncured Flashing Tape when conditions allow.
- Do not allow waste products (petroleum, grease, oil, solvents, vegetable or mineral oil, animal fats, etc.) or direct steam venting to come in contact with the Pre Cut Corners.
- KEEP OUT OF REACH OF CHILDREN

## **PROTECTION & SAFETY**

Mule-Hide maintains Safety Data Sheets on all of its non-exempt products. Safety Data Sheets contain health and safety information for your development of appropriate product handling procedures to protect your employees and customers. Mule-Hide's Safety Data Sheets should be read and understood by all of your supervisory personnel and employees before using Mule-Hide products in your facilities.

## **ADDITIONAL INFORMATION**

The information given on this PDS is subject to change without notice. Always check the Mule-Hide website at [www.mulehide.com](http://www.mulehide.com) for the latest information, changes and updates or contact Mule-Hide Products Company at 800-786-1492.

## **DISCLAIMER**

The statements provided concerning the material shown are intended as a guide for material usage and are believed to be true and accurate at the time of printing. No statement made by anyone may supersede this information, except when done in writing by Mule-Hide Products Co., Inc. Since the manner of use is beyond our control, Mule-Hide does not authorize anyone to make any warranty of merchantability or fitness for any particular purpose or any other warranty, guarantee or representation, expressed or implied, concerning this material. Buyer and user accept the product under these conditions and assume the risk of any failure, any injury person or property (including that of the user), loss or liability resulting from the handling, storage or use of the product whether or not it is handled, stored or used in accordance with the directions or specifications. Mule-Hide must be notified in writing of any claims and be given the opportunity to inspect the alleged failure before repairs are made.



# Product Data Sheet

## MULE-HIDE PREMOLDED EPDM PIPE BOOT

### PRODUCT DESCRIPTION

Mule-Hide Premolded EPDM Pipe Boots are economical, pre-fabricated flashings designed for single pipe penetrations on single-ply EPDM roofing systems. The premolded pipe boots have a butyl tape ring laminated to the bottom side of the three (3) inch base flange.

### BASIC USES

Mule-Hide's Premolded EPDM Pipe Boots will accommodate single pipe sizes from 1" to 6" in diameter. With their conical-shaped steps, the pipe boots will securely seal all single pipe penetrations. The large, double-thick, molded rib at the top of each step offers superior tear-resistance and reinforcement, as well as a cutting guide.

### TYPICAL PHYSICAL PROPERTIES

Physical Property	1" to 6"
Material	Molded EPDM
Color	White or Black
Size	1" to 6" (25 mm to 150 mm) pipe
Packaging	10 per carton
Weight	11 lbs per carton (5 kg)
Shelf Life	1 year



Typical properties and characteristics are based on samples tested and are not guaranteed for all samples of this product. This data and information is intended as a guide and does not reflect the specification or specification range for any particular property of this product.

### BENEFITS & SUPPLEMENTAL STATEMENTS

- Pipe boots are available with pre-applied butyl tape for easy installation and strong bonding to membrane
- Designed for use with Mule-Hide EPDM roofing membranes

### INSTALLATION INSTRUCTIONS

1. Remove all lead and other flashing materials. Remove any pipe insulation.
2. The entire surface where the Pipe Boot will be installed must be clean. The adhesive tape on the back of Pipe Boot will not adhere to dusted or dirty surfaces. Any residual contamination will reduce the bond strength of the adhesive.
3. Remove all foreign material from roofing membrane.
  - a. Remove excess mica dust from membrane surface by brooming or wiping with a clean, dry rag.
  - b. The use of Weathered Membrane Cleaner may be necessary. This process is essential on membrane that has been exposed for a number of weeks.  
Note: Permeation-resistant gloves (that meet ANSI/ISEA 105- 2005) are required for hand protection when cleaners or primers are being used.
  - c. Allow the membrane to dry thoroughly before proceeding.
4. Cut the Pipe Boot above the raised "ring" that is one size smaller than pipe diameter.
5. Pull Pipe Boot over pipe until base flange is in contact with the membrane.
6. Mark pipe around the top of the Pipe Boot.
7. Pull Pipe Boot upwards on pipe until mark on the pipe is visible.
8. Install Water Cut-Off Mastic below the mark, which indicates the top of the installed Pipe Boot.
9. Apply tape primer with a clean Scotch-Brite pad. Scrub the area of the membrane (where the Pipe Boot is to be applied) in a circular motion to achieve a thin, even coating on the membrane. The properly cleaned/primed area will be uniform in color without streaks and free of globs or puddles.



# Product Data Sheet

## MULE-HIDE PREMOLDED EPDM PIPE BOOT

### **INSTALLATION INSTRUCTIONS (continued)**

Note: The use of excessive amounts of primer will not enhance the adhesion of the Pipe Boot to the EPDM membrane. Use only the amount necessary to obtain 100% coverage of the area where the Pipe Boot will be applied.

10. Allow the tape primer to properly flash off until it does not transfer to a dry finger touch.
11. Install the Pipe Boot as soon as the primer flashes off to minimize potential dust contamination and promote adhesion in colder weather.
12. Pull the Pipe Boot back down over the pipe and into position.
13. Remove release liner from the taped flange and, using hand pressure, press tape into the primed area. Roll seam area with 2" roller.
14. Install a stainless steel clamping ring to the top of the Pipe Boot to provide constant compression of the Water Cut-Off Mastic.
15. When a field seam intersects a Pipe Boot, install a T-Joint patch.

*Review Mule-Hide specifications and details for additional installation information.*

### **PRECAUTIONS**

- All existing flashings, insulation and debris must be removed (including lead flashings)
- Temperature of projection must not exceed 180°F (82°C)
- Deck flanges of Pipe Boot must not be overlapped, cut or applied over any angle change.
- Ensure that clamping ring is properly sized

### **LEED Information**

Pre-consumer Recycled Content	2%
Post-consumer Recycled Content	0%
Manufacturing Location	Greenville, IL
Solar Reflectance Index (SRI)	N/A

### **PROTECTION & SAFETY**

Mule-Hide maintains Safety Data Sheets on all of its products. Safety Data Sheets contain health and safety information for your development of appropriate product handling procedures to protect your employees and customers. Mule-Hide's Safety Data Sheets should be read and understood by all of your supervisory personnel and employees before using Mule-Hide products in your facilities.

### **ADDITIONAL INFORMATION**

The information given on this PDS is subject to change without notice. Always check the Mule-Hide website at [www.mulehide.com](http://www.mulehide.com) for the latest information, changes and updates or contact Mule-Hide Products Company at 800-786-1492.

### **DISCLAIMER**

The statements provided concerning the material shown are intended as a guide for material usage and are believed to be true and accurate at the time of printing. No statement made by anyone may supersede this information, except when done in writing by Mule-Hide Products Co., Inc. Since the manner of use is beyond our control, Mule-Hide does not authorize anyone to make any warranty of merchantability or fitness for any particular purpose or any other warranty, guarantee or representation, expressed or implied, concerning this material. Buyer and user accept the product under these conditions and assume the risk of any failure, any injury person or property (including that of the user), loss or liability resulting from the handling, storage or use of the product whether or not it is handled, stored or used in accordance with the directions or specifications. Mule-Hide must be notified in writing of any claims and be given the opportunity to inspect the alleged failure before repairs are made.



## Product Data Sheet

# MULE-HIDE POLY ISO2™ ROOF INSULATION

### PRODUCT DESCRIPTION

Revision Date: June-2020

Mule-Hide Poly ISO 2™ (flat) and Poly ISO 2™ Tapered (Poly ISO 2™ insulations consist of a closed-cell polyisocyanurate foam core laminated to heavy, (non-asphaltic) glass fiber reinforced felt facers. Poly ISO 2™ insulations are compatible with all Mule-Hide membranes and accessories and are available in 20 and 25 psi densities



### BASIC USES

Mule-Hide Poly ISO 2™ insulation boards may be used for ballasted, mechanically attached and fully adhered single-ply roofing systems. Poly ISO 2™ insulation board may be installed over approved decks and substrates on new construction, tearoffs, and recover (retrofit) projects. Rated for use in UL Class A and FM Class 1 assemblies

### BENEFITS & SUPPLEMENTAL STATEMENTS

- Approved for direct application to steel decks
- Mule-Hide Poly ISO 2™ is manufactured using CFC-, HCFC-, and HFC-free foam blowing technology with zero ozone depletion potential (ODP) and virtually no (negligible) global warming potential (GWP).
- Available as 4' x 4' or 4' x 8' panels in Grade 2 (20 psi) or Grade 3 (25 psi)
- Thicknesses range from 1" to 4.5"
- Contains between 52.9% and 27.6% recycled materials by weight

### TYPICAL PHYSICAL PROPERTIES (flat and tapered)

Property*	Test Method	Typical Results
Dimensional Stability	ASTM D-2126	Less than 2% Linear Change
Compressive Strength	ASTM D-1621 (10% deformation)	20 PSI or 25 PSI
Water Absorption	ASTM C-209, ASTM D-2842	< 1.5%, < 3.5%
Moisture Vapor Transmission	ASTM E-96	Less than 1.5 Perm
Product Density	ASTM D-1622	Nominal 2.0 lbs per cubic foot
Flame Spread (foam core)	ASTM E-84 (full 10 min. test)	40 to 60*
Smoke Developed	ASTM E-84 (full 10 min. test)	50 to 170*
Service Temperature	---	-100°F to +250°F Max**
Tensile Strength	ASTM D-1623	>730 psf (35 kPa)

\* The numerical ratings are determined by ASTM Test Method E-84 are not intended to reflect hazards presented by this or any other material under actual fire conditions. A flame spread index of 75 or less and smoke development of 450 or less meet code requirements regarding flame spread and smoke development for foam plastic roof insulation. However, the codes exempt foam plastic insulation when used in roof deck constructions that comply as an assembly with FM 4450 or UL 1256 (see IBC, NBC, UBC and SBS Sections on Foam Plastic Insulation (Chapter 26). Smoke development does not apply to roofing.

\*\*ASTM C1289 Standard Specification for Faced Rigid Cellular Polyisocyanurate Thermal Insulation. The physical properties above are presented as typical average values as determined by accepted ASTM test methods and are subject normal manufacturing variation.

# MULE-HIDE POLY ISO2™ ROOF INSULATION

## TYPICAL PHYSICAL PROPERTIES – Continued

Mule-Hide Poly ISO 2™ (flat)					
LTTR R-Value <sup>1</sup>	Thickness <sup>2</sup>		RSI <sup>4</sup>	Flute Spanability	
	Inches	mm		Inches	mm
5.7	1.0	25.4	1.00	2.625	66.68
8.6	1.5	38.1	1.51	4.375	111.13
11.4	2.0	50.8	2.01	4.375	111.13
14.4	2.5	63.5	2.53	4.375	111.13
17.4	3.0 <sup>3</sup>	76.2	3.06	4.375	111.13
20.5	3.5 <sup>3</sup>	88.9	3.61	4.375	111.13
23.6	4.0 <sup>3</sup>	101.6	4.16	4.375	111.13

1. LTTR (Long Term Thermal Resistance) values were determined in accordance with CAN/ULC-S770 and ASTM C1289 (Revised Jan-2014), Annex A1. All test samples were third-party selected and tested by an accredited material testing laboratory. The LTTR results were reviewed and authorized by FM Approvals and certified by the PIMA Quality Mark Program
2. Other thicknesses available upon special request
3. Multi-layer application is suggested when the insulation thickness exceeds 2.7".
4. RSI is the metric expression of R-value ( $m^2 * K/W$ )

LTTR Value	ASTM C1289-11
20	2 layers of 1.8" Poly ISO
25	2 layers of 2.2" Poly ISO
30	2 layers of 2.6" Poly ISO
35	2 layers of 3.1" Poly ISO
40	2 layers of 3.5" Poly ISO

## TYPICAL PHYSICAL PROPERTIES – Continued

## SUPPLEMENTAL INFORMATION

Mule-Hide Poly ISO 2™ Tapered						
Panel Label	AVERAGE		THICKNESS <sup>3</sup>		SLOPE	
	LTTR <sup>1</sup>	RSI <sup>2</sup>	IN	MM	Per Ft.	Percent
AA	4.3	0.76	0.5 – 1.0	12 - 25	1/8"	1%
A	7.1	1.25	1.0 – 1.5	25 - 38	1/8"	1%
B	10.0	1.76	1.5 – 2.0	38 – 50	1/8"	1%
C	12.9	2.27	2.0 – 2.5	50 – 63	1/8"	1%
X	5.7	1.00	0.5 – 1.5	12 – 38	1/4"	2%
Y	11.4	2.01	1.5 - 2.5	38 – 63	1/4"	2%
Q	8.6	1.51	0.5 – 2.5	12 – 63	1/2"	4%

1. LTTR (Long Term Thermal Resistance) values were determined in accordance with CAN/ULC-S770 and ASTM C1289 (Revised Jan-2014), Annex A1. All test samples were third-party selected and tested by an accredited material testing laboratory. The LTTR results were reviewed and authorized by FM Approvals and certified by the PIMA Quality Mark Program
2. RSI is the metric expression of R-value ( $m^2 * K/W$ )
3. Other thicknesses MAY available upon special request

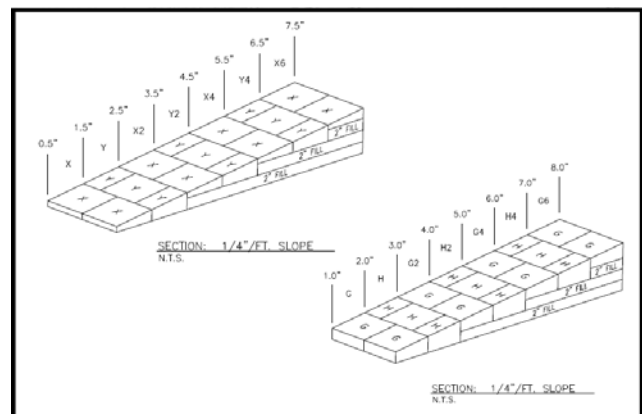
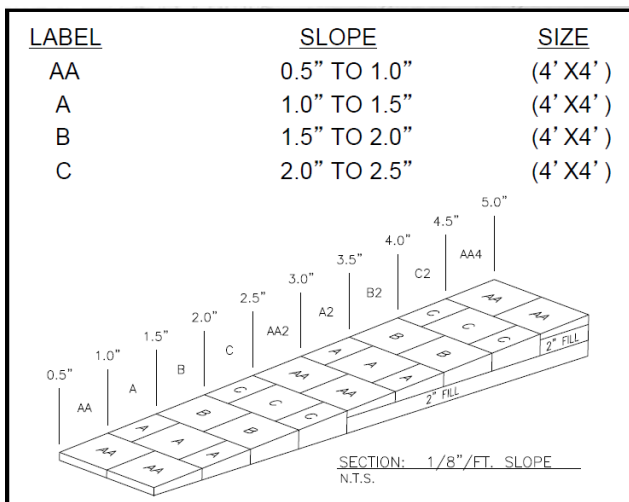
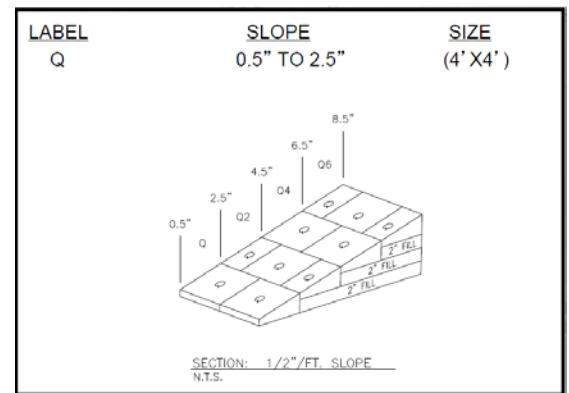

# MULE-HIDE POLY ISO2™ ROOF INSULATION

---

## **PACKAGING**

Factory applied packaging is only intended for protection during transit. When stored outside or at the job site, the insulation must be stored at least 4" above ground level and completely covered with a weatherproof covering such as a tarpaulin. Warning - Do Not Leave Exposed: This product will burn if exposed to an ignition source of sufficient heat and intensity, or an open flame.

## **CODE APPROVALS/COMPLIANCE**

Poly ISO 2™ complies with the requirements of the following specifications, test and code requirements when properly installed.

- \* ASTM C 1289, Type II, Class 1, Grade 2 (20 psi) or Grade 3 (25 psi)
- \* CAN/ULC-S704 Type 2, Class 3 or Type 3, Class 3
- \* CCMC No. 12464-L
- \* FM Standard 4450/4470 Approval, Class 1
- \* UL Standard 1256 Classification
- \* UL Standard 790 Classification
- \* UL Standard 263 Fire Resistance Classification
- \* UL Standard 1897 Uplift Resistance
- \* IBC Chapter 26 and NBC Sections on Foam Insulation
- \* California State Insulation Quality Standards and Title 25 Foam Flammability Criteria (license #T1231)
- \* Has achieved GREENGUARD GOLD Certification UL 2818

**Mule-Hide Poly ISO 2™ is manufactured using CFC-, HCFC-, and HFC-free foam blowing technology with zero ozone depletion potential (ODP) and virtually no (negligible) global warming potential (GWP).**

## **INSTALLATION INSTRUCTIONS**

**Ballasted Single-Ply Membrane Systems** - Mule-Hide Poly ISO 2™ does not require attachment to the deck in this system. All boards must be tightly fitted together to prevent movement, separation or damage during the installation of the membrane system. All gaps greater than 1/4" must be filled. After the membrane is installed, sufficient amounts of ballast must be applied to prevent membrane and insulation movement. Refer to the Mule-Hide Manual and FM Loss Prevention Data Sheet 1-29 for information regarding ballasting guidelines.

**Mechanically Attached Single-Ply Membrane Systems** - Mule-Hide Poly ISO 2™ should be attached with Mule-Hide fasteners and insulation plates (or FM Approved fasteners) using a minimum of 4 fasteners per 4'x 4' board (1 fastener per 4 square feet) and a minimum of 6 fasteners per 4'x 8' board (1 fastener per 5.33 square feet). Refer to the Mule-Hide Manual for proper fastener placement.

**Fully Adhered Single-Ply Membrane Systems** - Mule-Hide Poly ISO 2™ should be installed with the perforated side down. Insulation attachment will vary depending upon insulation thickness and job requirements. If the top layer is less than 2" thick, install a minimum of 8 fasteners per 4'x 4' board (1 fastener per 2 square feet) and a minimum of 16 fasteners per 4'x 8' board (1 fastener per 2 square feet). If the top layer is 2" thick or thicker, install 4 fasteners per 4' x 4' or 8 fasteners per 4' x 8' insulation board. Refer to the Mule-Hide Manual for proper fastener density and placement. Additional fastening may be required for certain job conditions.

In some instances hot steep asphalt or insulation adhesive may be used to attach the Mule-Hide Poly ISO 2™ to approved concrete decks. Only 4'x 4' boards may be used. Contact Mule-Hide's Technical Department for specific requirements and procedures.



# MULE-HIDE POLY ISO2™ ROOF INSULATION

---

## **PROTECTION & SAFETY**

Mule-Hide maintains Safety Data Sheets on all of its products. Safety Data Sheets contain health and safety information for your development of appropriate product handling procedures to protect your employees and customers. Mule-Hide's Safety Data Sheets should be read and understood by all of your supervisory personnel and employees before using Mule-Hide products in your facilities.

## **ADDITIONAL INFORMATION**

The information given on this PDS is subject to change without notice. Always check the Mule-Hide website at [www.mulehide.com](http://www.mulehide.com) for the latest information, changes and updates or contact Mule-Hide Products Company at 800-786-1492.

## **DISCLAIMER**

The statements provided concerning the material shown are intended as a guide for material usage and are believed to be true and accurate at the time of printing. No statement made by anyone may supersede this information, except when done in writing by Mule-Hide Products Co., Inc. Since the manner of use is beyond our control, Mule-Hide does not authorize anyone to make any warranty of merchantability or fitness for any particular purpose or any other warranty, guarantee or representation, expressed or implied, concerning this material. This product may be eligible for a Mule-Hide warranty, please check the Mule-Hide website at [www.mulehide.com](http://www.mulehide.com) or contact Mule-Hide directly at 800-786-1492 for details. Buyer and user accept the product under these conditions and assume the risk of any failure, any injury person or property (including that of the user), loss or liability resulting from the handling, storage or use of the product whether or not it is handled, stored or used in accordance with the directions or specifications. Mule-Hide must be notified in writing of any claims and be given the opportunity to inspect the alleged failure before repairs are made.



# Poly ISO 1

## Roof Insulation



### PRODUCT DATA SHEET

#### DESCRIPTION

MuleHide Poly ISO 1™ polyisocyanurate insulation (flat or tapered) is a closed-cell polyisocyanurate foam core laminated to (non-asphaltic) glass fiber reinforced felt facers. Featuring glass facer with a light and dark side, allowing the installer to choose which side to install up to control flash-off times in fully adhered applications. MuleHide Poly ISO 1 is compatible with all MuleHide membranes and accessories. Available in 20 psi and 25 psi.

#### BASIC USES

MuleHide Poly ISO 1 insulation board may be used for ballasted, mechanically attached and fully adhered single-ply roofing systems. Poly ISO 1 insulation board may be installed over approved decks and substrates on new construction, tearoffs, and recover (retrofit) projects. Poly ISO 1 insulation board may be used in UL Class A and FM Class 1 assemblies.

#### BENEFITS AND SUPPLEMENTAL STATEMENTS

- Approved for direct application to steel decks
- MuleHide Poly ISO 1™ is manufactured with NexGen Chemistry: Contains no CFCs, HCFCs, is Zero ODP, EPA Compliant and has virtually no GWP
- Available as 4' x 4' or 4' x 8' panels in Grade 2 (20 psi) or Grade 3 (25 psi)
- Available in 4' x 12' panels in Grade 2 (20 psi) in the following thickness: 1.5", 1.75", 2.0", 2.2", 2.5", 2.6", 3.0", 3.3" and 3.5"

#### PACKAGING

Factory applied packaging is only intended for protection during transit. When stored outside or at the job site, the insulation must be stored at least 4" above ground level and completely covered with a weatherproof covering such as a tarpaulin. Warning - Do Not Leave Exposed: This product will burn if exposed to an ignition source of sufficient heat and intensity, or an open flame.

#### CODE APPROVALS/COMPLIANCE

Poly ISO 1™ complies with the requirements of the following specifications, test and code requirements when properly installed

- Federal Specification HH-I-1972/GEN and HH-I-1972/2, Class 1
- ASTM C 1289 Type II, Class 1, Grade 2 (20 psi), Grade 3 (25 psi)
- FM Standard 4450/4470 Approval, Class 1
- UL Standard 1256 Classification
- UL Standard 790 Classification
- UL Standard 263 Fire Resistance Classification

#### TYPICAL PHYSICAL PROPERTIES

Property	Test Method	Typical Result
Dimensional Stability	ASTM D2126	2% Linear Change (7 days)
Compressive Strength	ASTM D1621	20 PSI (Grade 2) 25 PSI (Grade 3)
Water Absorption	ASTM D209	< 1% By Volume
Water Vapor Transmission	ASTM E96	< One (1) Perm
Service Temperature	--	-100°F to 250°F Max
Flame Spread (Foam Core)	ASTM E84	< 75*
Smoke Development	ASTM E84	< 450*

The physical properties above are presented as typical average values as determined by accepted ASTM test methods and are subject to change. All information can be confirmed by contacting MuleHide Products.

\*The numerical ratings are determined by ASTM Test Method E-84 are not intended to reflect hazards presented by this or any other material under actual fire conditions. A flame spread index of 75 or less and smoke development of 450 or less meet code requirements regarding flame spread and smoke development for foam plastic roof insulation. However, the codes exempt foam plastic insulation when used in roof deck constructions that comply as an assembly with FM 4450 or UL 1256 (see IBC, NBC, UBC and SBS Sections on Foam Plastic Insulation (Chapter 26). Smoke development does not apply to roofing.

#### TYPICAL PHYSICAL PROPERTIES (CONTINUED)

Nominal Thickness*	(mm)	LTR R-Value	C-Value	Metal Deck Max. Flute
0.5	13	2.8	.350	2-5/8
1.0	25	5.7	.175	2-5/8
1.5†	38	8.6	.116	4-3/8
1.75†	44	10.0		
1.8	46	10.3	.097	4-3/8
2.0†	51	11.4	.088	4-3/8
2.2†	56	12.6		
2.5†	64	14.4	.069	4-3/8
2.6†	66	15.0	.067	4-3/8
3.0†	76	17.4	.057	4-3/8
3.3†	84	19.2		
3.5†	89	20.5	.049	4-3/8
3.8	97	22.3	.045	4-3/8
4.0	102	23.6	.042	4-3/8
4.3	109	25.5	.039	4-3/8
4.5	114	26.8	.037	4-3/8

Long Term Thermal Resistance Values are based on ASTM C1289 (revised Jan-2014) and CAN/ULC S770 which provides for a 15-year time weighted average.

\*Other thicknesses available upon special request.  
†4'x12' panel



# Poly ISO 1

## Roof Insulation



### PRODUCT DATA SHEET

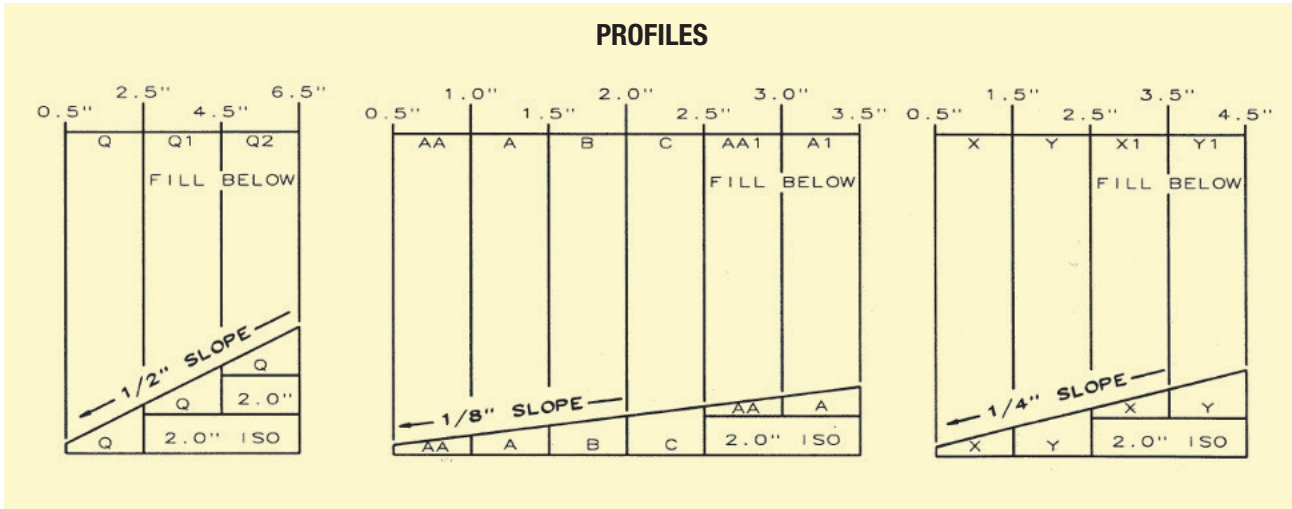

### INSTALLATION INSTRUCTIONS

**Ballasted Single-Ply Membrane Systems** - MuleHide Poly ISO 1™ does not require attachment to the deck in this system. All boards must be tightly fitted together to prevent movement, separation or damage during the installation of the membrane system. All gaps greater than 1/4" must be filled. After the membrane is installed, sufficient amounts of ballast must be applied to prevent membrane and insulation movement. Refer to the MuleHide Manual and FM Loss Prevention Data Sheet 1-29 for information regarding ballasting guidelines.

**Mechanically Attached Single-Ply Membrane Systems** - MuleHide Poly ISO 1™ should be attached with MuleHide fasteners and insulation plates (or FM Approved fasteners) using a minimum of 4 fasteners per 4'x 4' board (1 fastener per 4 square feet) and a minimum of 6 fasteners per 4'x 8' board (1 fastener per 5.33 square feet). Refer to the MuleHide Manual for proper fastener placement. When using 4'x12' Poly-Iso 1 boards, 6 fasteners and plates per board may be acceptable on MuleHide Products system warranties up to 20 years (minimum 1.5" board thickness). Not acceptable on Recover/No Tear-Off projects.

**Fully Adhered Single-Ply Membrane Systems** - MuleHide Poly ISO 1™ should be installed with the perforated side down. Insulation attachment will vary depending upon insulation thickness and job requirements. If the top layer is less than 2" thick, install a minimum of 8 fasteners per 4'x 4' board (1 fastener per 2 square feet) and a minimum of 16 fasteners per 4'x 8' board (1 fastener per 2 square feet). If the top layer is 2" thick or thicker, install 4 fasteners per 4' x 4' or 8 fasteners per 4' x 8' insulation board. Refer to the MuleHide Manual for proper fastener density and placement. Additional fastening may be required for certain job conditions. In some instances hot steep asphalt or insulation adhesive may be used to attach the MuleHide Poly ISO 1 to approved concrete decks. Only 4'x 4' boards may be used. Contact MuleHide's Technical Department for specific requirements and procedures. 4'x12' Polyiso 1 boards shall be fastened at the same or greater rate per square foot of board.

### PROTECTION & SAFETY

MuleHide maintains Safety Data Sheets on all of its non-exempt products. Safety Data Sheets contain health and safety information for your development of appropriate product handling procedures to protect your employees and customers. MuleHide's Safety Data Sheets should be read and understood by all of your supervisory personnel and employees before using MuleHide products in your facilities.

### ADDITIONAL INFORMATION

The information given on this PDS is subject to change without notice. Always check the MuleHide website at [www.mulehide.com](http://www.mulehide.com) for the latest information, changes and updates or contact MuleHide at 800-786-1492.

### DISCLAIMER

The statements provided concerning the material shown are intended as a guide for material usage and are believed to be true and accurate at the time of printing. No statement made by anyone may supersede this information, except when done in writing by Mule-Hide Products Co., Inc. ("MuleHide"). Since the manner of use is beyond our control, MuleHide does not authorize anyone to make any warranty of merchantability or fitness for any particular purpose or any other warranty, guarantee or representation, expressed or implied, concerning this material. This product may be eligible for a MuleHide warranty, please check the MuleHide website at [www.mulehide.com](http://www.mulehide.com) or contact MuleHide directly at 800-786-1492 for details. Buyer and user accept the product under these conditions and assume the risk of any failure, any injury person or property (including that of the user), loss or liability resulting from the handling, storage or use of the product whether or not it is handled, stored or used in accordance with the directions or specifications. MuleHide must be notified in writing of any claims and be given the opportunity to inspect the alleged failure before repairs are made.



# MULE-HIDE 3” INSULATION PLATE

## PRODUCT DESCRIPTION

Mule-Hide’s 3” Insulation Plates are round Galvalume coated metal plates with reinforcing ribs for superior wind uplift resistance

## BASIC USES

Mule-Hide’s 3” Insulation Plates are designed specifically for the mechanical attachment of Mule-Hide’s Poly ISO 1 and Poly ISO 2 insulation and other FM Approved insulation / cover boards.

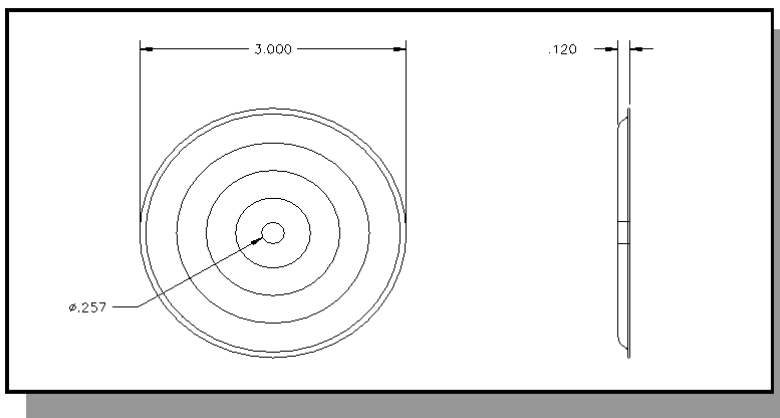

## SPECIFICATIONS

Material:	26 ga. Galvalume coated metal
Coating:	Galvalume AZ-50
Corrosion:	Meets FM 4470, ASTM D 6294 & DIN 50018
LEED Eligible Recycle Content	49%
Manufacturing Location	Cleveland, OH

## CODE APPROVALS/COMPLIANCE

Mule-Hide HDP Fasteners comply with the requirements of the following specifications, test and code requirements when properly installed.

\* FM Standard 4450/4470 Approval    \* Metro-Dade Approved    \*Florida Product Approval

## PACKAGING

Packaged in cartons of 1,000, approximate weight is 40# per box.

## INSTALLATION INSTRUCTIONS

Install Mule-Hide 3” Insulation Plates with head indentation facing upward.  
Secure 3” insulation plate with Mule-Hide Drill Point, HDP or EHD fasteners in to substrate.  
Use eye protection when installing fasteners.

## PROTECTION & SAFETY

# MULE-HIDE 3" INSULATION PLATE

---

Mule-Hide maintains Safety Data Sheets on all of its non-exempt products. Safety Data Sheets contain health and safety information for your development of appropriate product handling procedures to protect your employees and customers. Mule-Hide's Safety Data Sheets should be read and understood by all of your supervisory personnel and employees before using Mule-Hide products in your facilities.

## **ADDITIONAL INFORMATION**

The information given on this PDS is subject to change without notice. Always check the Mule-Hide website at [www.mulehide.com](http://www.mulehide.com) for the latest information, changes and updates or contact Mule-Hide Products Company at 800-786-1492.

## **DISCLAIMER**

The statements provided concerning the material shown are intended as a guide for material usage and are believed to be true and accurate at the time of printing. No statement made by anyone may supersede this information, except when done in writing by Mule-Hide Products Co., Inc. Since the manner of use is beyond our control, Mule-Hide does not authorize anyone to make any warranty of merchantability or fitness for any particular purpose or any other warranty, guarantee or representation, expressed or implied, concerning this material. This product may be eligible for a Mule-Hide warranty, please check the Mule-Hide website at [www.mulehide.com](http://www.mulehide.com) or contact Mule-Hide directly at 800-786-1492 for details. Buyer and user accept the product under these conditions and assume the risk of any failure, any injury person or property (including that of the user), loss or liability resulting from the handling, storage or use of the product whether or not it is handled, stored or used in accordance with the directions or specifications. Mule-Hide must be notified in writing of any claims and be given the opportunity to inspect the alleged failure before repairs are made.



# MULE-HIDE 2.4" SEAM PLATE

## PRODUCT DESCRIPTION

Rev. May 2020

Mule-Hide's 2.4" Seam Plates are round Galvalume coated metal plates with (14) barbed anchors and reinforcing ribs for superior wind uplift resistance

## BASIC USES

Mule-Hide's 2.4" Seam Plates are designed for the mechanical attachment of the Mule-Hide Reinforced EPDM, PVC and TPO membranes. The 2.4" Seam Plates are attached with Mule-Hide HDP Fasteners or EHD Fasteners. In addition to securing mechanically attached reinforced membranes, our 2.4" Seam Plates can be used with our reinforced 6" wide RMS, or our 6" wide and 10" wide RUSS™ Strips.



## SPECIFICATIONS

Material:	20 ga. Galvalume coated metal
Coating:	Galvalume AZ-55 meeting ASTM A 792 Grade 50A
Corrosion:	Meets requirements of FM 4470, ASTM D6294 and DIN 50018
LEED Eligible Recycle Content	49%
Manufacturing Location	Cleveland, OH

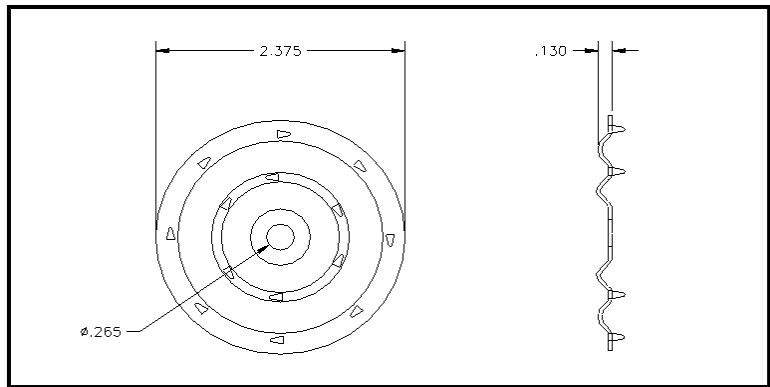

## CODE

## APPROVALS/COMPLIANCE

Mule-Hide HDP Fasteners comply with the requirements of the following specifications, test and code requirements when properly installed.

\* FM Standard 4450/4470 Approval   \* Metro-Dade Approved   \*Florida Product Approval

## PACKAGING

Packaged in buckets of 1,000, approximate weight is 52# per box.

## INSTALLATION INSTRUCTIONS

Install Mule-Hide 2.4" Seam Plates with barbs facing toward membrane (see appropriate detail drawing). Secure 2.4" Seam Plate with Mule-Hide HDP or EHD fasteners in to substrate. Use eye protection when installing fasteners.

# MULE-HIDE 2.4" SEAM PLATE

---

## **PROTECTION & SAFETY**

Mule-Hide maintains Safety Data Sheets on all of its non-exempt products. Safety Data Sheets contain health and safety information for your development of appropriate product handling procedures to protect your employees and customers. Mule-Hide's Safety Data Sheets should be read and understood by all of your supervisory personnel and employees before using Mule-Hide products in your facilities.

## **ADDITIONAL INFORMATION**

The information given on this PDS is subject to change without notice. Always check the Mule-Hide website at [www.mulehide.com](http://www.mulehide.com) for the latest information, changes and updates or contact Mule-Hide Products Company at 800-786-1492.

## **DISCLAIMER**

The statements provided concerning the material shown are intended as a guide for material usage and are believed to be true and accurate at the time of printing. No statement made by anyone may supersede this information, except when done in writing by Mule-Hide Products Co., Inc. Since the manner of use is beyond our control, Mule-Hide does not authorize anyone to make any warranty of merchantability or fitness for any particular purpose or any other warranty, guarantee or representation, expressed or implied, concerning this material. This product may be eligible for a Mule-Hide warranty, please check the Mule-Hide website at [www.mulehide.com](http://www.mulehide.com) or contact Mule-Hide directly at 800-786-1492 for details. Buyer and user accept the product under these conditions and assume the risk of any failure, any injury person or property (including that of the user), loss or liability resulting from the handling, storage or use of the product whether or not it is handled, stored or used in accordance with the directions or specifications. Mule-Hide must be notified in writing of any claims and be given the opportunity to inspect the alleged failure before repairs are made.





# DensDeck® Prime Roof Board

## PRODUCT DESCRIPTION

Revision Date: February 2021

DensDeck Prime Roof Board's patented design features a gypsum core with embedded glass mat facers on the top and bottom of the board. DensDeck Prime can be used in a variety of commercial roof systems and provides an excellent thermal barrier as well as exceptional fire, moisture, and wind uplift resistance properties.

DensDeck Prime is typically used as a cover board over insulation in fully adhered EPDM, TPO, and PVC applications. It is compatible with solvent-based bonding adhesives. For applications in which Helix Max is used to attach insulation and a vapor barrier is specified, DensDeck Prime can be used as a base layer for Mule-Hide's F5 Air and Vapor Barrier (in conjunction with Aeroweb). DensDeck Prime is also compatible with hot asphalt and can be used as a membrane underlayment in hot mopped roofing systems or as a parapet wall substrate in all systems.



## TYPICAL PHYSICAL PROPERTIES

Properties	1/4" (6.4 mm)	1/2" (12.7 mm)	5/8" (15.9 mm)
Thickness, nominal	1/4" (6.4 mm) ± 1/16" (1.6 mm)	1/2" (12.7 mm) ± 1/32" (0.8 mm)	5/8" (15.9 mm) ± 1/32" (0.8 mm)
Width, Standard	4' (1219 mm) ± 1/8" (3 mm)	4' (1219 mm) ± 1/8" (3 mm)	4' (1219 mm) ± 1/8" (3 mm)
Length, Standard	4' (1219 mm) 8' (2438 mm) ± 1/4" (6.4 mm)	4' (1219 mm) 8' (2438 mm) ± 1/4" (6.4 mm)	4' (1219 mm) 8' (2438 mm) ± 1/4" (6.4 mm)
Weight, nominal, lbs./sq. ft. (Kg/m <sup>2</sup> ) <sup>7</sup>	1.2 (5.9)	2.0 (9.8)	2.5 (12.2)
Surfacing	Fiberglass Mat with non-asphaltic coating	Fiberglass Mat with non-asphaltic coating	Fiberglass Mat with non-asphaltic coating
Flexural Strength <sup>1</sup> , parallel, lbf. Min. (N)	≥40 (178)	≥80 (356)	≥100 (444)
Flute Spanability <sup>2</sup>	2-5/8" (67 mm)	5" (127mm)	8" (203mm)
Permeance <sup>3</sup> , perms (ng/Pa• S• m <sup>2</sup> )	>30 (1710)	>23 (1300)	>17 (970)
R Value <sup>4</sup> , ft <sup>2</sup> • °F• hr/BTU (m <sup>2</sup> K/W)	0.28	0.56	0.67
Linear Variation with Change in Temp., in/in °F (mm/mm/°C)	8.5 x 10 <sup>-6</sup> (15.3 x 10 <sup>-6</sup> )	8.5 x 10 <sup>-6</sup> (15.3 x 10 <sup>-6</sup> )	8.5 x 10 <sup>-6</sup> (15.3 x 10 <sup>-6</sup> )
Linear Variation with Change in Moisture	6.25 x 10 <sup>-6</sup>	6.25 x 10 <sup>-6</sup>	6.25 x 10 <sup>-6</sup>
Water Absorption <sup>5</sup> , %	5	5	5
Compressive Strength <sup>6</sup> , psi nominal	900	900	900
Surface Water Absorption, rams, nominal <sup>1</sup>	1.0	1.0	1.0
Flame Spread, Smoke Developed (ASTM E84)	0/0	0/0	0/0
Bending Radius	4' (1219 mm)	6' (1829 mm)	8' (2438 mm)

<sup>1</sup> Tested in accordance with ASTM C473 method B.

<sup>2</sup> Tested in accordance with ASTM E661.

<sup>3</sup> Tested in accordance with ASTM E96 (dry cup method)

<sup>4</sup> Tested in accordance with ASTM C518 (heat flow meter).

<sup>5</sup> Tested in accordance with ASTM C1177.

<sup>6</sup> Tested in accordance with ASTM C473.

<sup>7</sup> Represents approximate weight for design and shipping purposes. Actual weight may vary based on manufacturing Location and other factors.

# DensDeck<sup>®</sup> Prime Roof Board

## **BENEFITS AND SUPPLEMENTAL STATEMENTS**

- UL code ratings available for (class A, B, C) unlimited slopes and wood decks
- FM Approved
- Improves resistance to foot traffic and hail damage
- Excellent wind uplift ratings
- Resistant to deterioration, warping, and jobsite damage
- 5/8" DensDeck Prime can replace any generic Type "X" gypsum board in any roof assembly in the UL Fire Resistance Directory under the prefix "P"

## **PACKAGING**

Factory applied packaging is only intended for protection during transit.

1/4" 4'x4' Panels	60 pieces	1152 lbs
1/4" 4'x8' Panels	42 pieces	1613 lbs
1/2" 4'x4' Panels	50 pieces	1600 lbs
1/2" 4'x8' Panels	30 pieces	1920 lbs
5/8" 4'x4' Panels	40 pieces	1600 lbs
5/8" 4'x8' Panels	30 pieces	2400 lbs

## **STORAGE**

When stored outside or at the job site, the roof board must be stored at least 4" above ground level and completely covered with a weatherproof covering such as a tarpaulin. **Warning - Do Not Leave Exposed:** Product must be kept dry at all times. Install only as much roof board as can be covered the same day by the roofing system.

## **CODE APPROVALS/COMPLIANCE**

- Manufactured to conform to ASTM C-1177
- Tested in accordance with ASTM E-84 or CAN/ULC-S102
- Non-combustible when tested in accordance with ASTM E-136
- UL code approval for current class A, B, C approvals UL Class A

## **INSTALLATION INSTRUCTIONS**

DensDeck Prime may be secured with Helix Max Adhesive, fastened in accordance with an approved fastening pattern, or mopped with Type III or IV asphalt.

Maximum asphalt application temperatures of 425°F (218°C) to 450°F (232°C) are recommended. Application temperatures above these recommended temperatures may adversely affect roof system performance.

Edge joints should be located on and parallel to deck ribs. End joints of adjacent lengths should be staggered.

1. This material shall be installed with ends and edges butted tightly.
2. When installed over combustible wood decks or insulations, all joints should be staggered.
3. In accordance with approved shop drawings, FM Approved fasteners shall be installed with plates through the roof board, flush with the surface.

*Review Mule-Hide specifications and details for complete installation information.*

## **PRECAUTIONS**

- When applying solvent-based adhesives or primers, allow sufficient time for the solvents to flash off.
- 1/4" DensDeck is not recommended for vertical parapet applications or for asphalt attachment.
- In ballasted roofing systems, DensDeck is not an acceptable membrane underlayment.

# DensDeck® Prime Roof Board

## LEED INFORMATION

Manufacturing Location <sup>1</sup>	Total Recycled Content <sup>2</sup>	Pre-Consumer Recycled Content <sup>2</sup>	Post-Consumer Recycled Content <sup>2</sup>
Acme, TX	0%	0%	0%
Antioch, CA	0%	0%	0%
Ft. Dodge, IA	0%	0%	0%
Las Vegas, NV	0%	0%	0%
Lovell, WY	0%	0%	0%
Newington, NH	30%	30%	0%
Savannah, GA	0%	0%	0%
Tacoma, WA	14%	14%	0%
Wheatfield, IN	94%	94%	0%

<sup>1</sup> Manufacturing locations subject to change. Please visit [www.gpgypsum.com](http://www.gpgypsum.com) and click on Sustainability.

<sup>2</sup> Recycled content subject to change + / - 1.0%.

<sup>3</sup> Based on ICC Evaluation Service Verification of Attributes Report for Dens® brand products issued August 1, 2009. [www.saveprogram.icc-es.org](http://www.saveprogram.icc-es.org)

## PROTECTION & SAFETY

Mule-Hide maintains Safety Data Sheets on all of its non-exempt products. Safety Data Sheets contain health and safety information for your development of appropriate product handling procedures to protect your employees and customers. Mule-Hide's Safety Data Sheets should be read and understood by all of your supervisory personnel and employees before using Mule-Hide products in your facilities.

## ADDITIONAL INFORMATION

The information given on this PDS is subject to change without notice. Always check the Mule-Hide website at [www.mulehide.com](http://www.mulehide.com) for the latest information, changes and updates or contact Mule-Hide Products Company at 800-786-1492.

DensDeck is a registered trademark of Georgia-Pacific Gypsum LLC.

## DISCLAIMER

The statements provided concerning the material shown are intended as a guide for material usage and are believed to be true and accurate at the time of printing. No statement made by anyone may supersede this information, except when done in writing by Mule-Hide Products Co., Inc. Since the manner of use is beyond our control, Mule-Hide does not authorize anyone to make any warranty of merchantability or fitness for any particular purpose or any other warranty, guarantee or representation, expressed or implied, concerning this material. This product may be eligible for a Mule-Hide warranty, please check the Mule-Hide website at [www.mulehide.com](http://www.mulehide.com) or contact Mule-Hide directly at 800-786-1492 for details. Buyer and user accept the product under these conditions and assume the risk of any failure, any injury person or property (including that of the user), loss or liability resulting from the handling, storage or use of the product whether or not it is handled, stored or used in accordance with the directions or specifications. Mule-Hide must be notified in writing of any claims and be given the opportunity to inspect the alleged failure before repairs are made.



# USG SECUROCK® Gypsum-Fiber Roof Board

## PRODUCT DESCRIPTION

USG SECUROCK Gypsum-Fiber Roof Board is a high-performance roof board for use in low-slope roofing systems. Its unique, fiber-reinforced, homogenous composition means the panel is strong and water-resistant all the way through to its core. USG SECUROCK Gypsum-Fiber Roof Board provides low absorption and an exceptional bond in adhered systems, and, because of its homogenous composition, achieves high wind uplift ratings with no risk of facer delamination. Made from 97% recycled material, USG SECUROCK Gypsum-Fiber Roof Board combines superior performance with sustainable design for single-ply roofing systems.

Revision Date: February 2021



## TYPICAL PROPERTIES AND CHARACTERISTICS

Properties	1/4" (6.6 mm)	3/8" (19.5 mm)	1/2" (12.7 mm)	5/8" (15.9 mm)
Thickness, nominal	1/4" (6.4 mm) ± 1/16" (1.6 mm)	3/8" (19.5 mm) ± 1/16" (1.6 mm)	1/2" (12.7 mm) ± 1/32" (0.8 mm)	5/8" (15.9 mm) ± 1/32" (0.8 mm)
Width, Standard	4' (1220 mm)	4' (1220 mm)	4' (1220 mm)	4' (1220 mm)
Length, Standard	4' (1220 mm) and 8' (2438 mm)	4' (1220 mm) and 8' (2438 mm)	4' (1220 mm) and 8' (2438 mm)	4' (1220 mm) and 8' (2438 mm)
Weight, nominal, lbs./sq. ft.	1.57	1.96	3.2	3.2
Flexural Strength, parallel, lbf. min. per ASTM C 473	40	70	110	161
Compressive Strength, psi nominal	1800	1800	1800	1800
Flute Spanability per ASTM E 661	2-5/8"	5"	8"	10"
Permeance, perms per ASTM E 96	30	26	26	24
R Value per ASTM C 518	0.2	0.3	0.5	0.6
Coefficient of thermal expansion, inches/ inch • °F, per ASTM E 831	8.0 x 10 <sup>-6</sup>	8.0 x 10 <sup>-6</sup>	8.0 x 10 <sup>-6</sup>	8.0 x 10 <sup>-6</sup>
Linear Variation with Change in Moisture, inches/inch • %RH, per ASTM E 831	8.0 x 10 <sup>-6</sup>	8.0 x 10 <sup>-6</sup>	8.0 x 10 <sup>-6</sup>	8.0 x 10 <sup>-6</sup>
Water Absorption, % max, per ASTM C 473	10	10	10	10
Surface Water Absorption, nominal grams, per ASTM C 473	1.6	1.6	1.6	1.6
Mold Resistance per ASTM D 3273*	10	10	10	10
Bending Radius	25'	25'	25'	25'

Typical properties and characteristics are based on samples tested and are not guaranteed for all samples of this product. This data and information is intended as a guide and does not reflect the specification range for any particular property of this product.

\*ASTM D3273 Mold Resistance Testing - In independent lab tests conducted on SECUROCK Gypsum-Fiber roof board and SECUROCK Glass-Mat roof board at the time of manufacture per ASTM D3273 Standard Test Method for Resistance to Growth of Mold on the Surface of Interior Coatings in an Environmental Chamber, both panels scored a 10. The ASTM lab test may not accurately represent the mold performance of building materials in actual use. Given unsuitable project conditions during storage, installation or after completion, any building material can be overwhelmed by mold. To manage the growth of mold, the best and most cost-effective strategy is to protect building products from water exposure during storage and installation and after completion of the building. This can be accomplished by using good design and construction practices.

## BENEFITS AND SUPPLEMENTAL STATEMENTS

- Exceptional bond and low absorption in adhered systems
- Resistant to moisture and mold
- Exceptional wind uplift performance
- Manufactured from 97% recycled material
- Provides protection from hail and foot traffic when adhered with insulation adhesive

# USG SECUROCK<sup>®</sup> Gypsum-Fiber Roof Board

## PACKAGING

Factory applied packaging is only intended for protection during transit.

1/4" 4'x4' Panels	100 pieces	2512 lbs
1/4" 4'x8' Panels	50 pieces	2575 lbs
3/8" 4'x4' Panels	80 pieces	2509 lbs
3/8" 4'x8' Panels	40 pieces	2575 lbs
1/2" 4'x4' Panels	60 pieces	2650 lbs
1/2" 4'x8' Panels	30 pieces	2725 lbs
5/8" 4'x4' Panels	48 pieces	2458 lbs
5/8" 4'x8' Panels	24 pieces	2525 lbs

## STORAGE

When stored outside or at the job site, the roof board must be stored at least 4" above ground level and completely covered with a weatherproof covering such as a tarpaulin. **Warning - Do Not Leave Exposed:** Product must be kept dry at all times. Install only as much roof board as can be covered the same day by the roofing system.

## CODE APPROVALS/COMPLIANCE

- Surface Burning Characteristics and Non-Combustibility in accordance with ASTM E84 (CAN/ULC-S102).
- 1/2" and 5/8" thickness – UL Class A in accordance with UL790 (CAN/ULC-S107) (ASTM E108). See the UL Building Materials Directory for more information.
- 5/8" thickness – Meets requirements of Type X per ASTM C1278 and may be used in ULP series designs as a thermal barrier.
- Meets FM Class 1 (FM 4450 and FM 4470).
- Manufactured to conform to ASTM C1278, "Standard Specification for Fiber-Reinforced Gypsum Panel."

## INSTALLATION INSTRUCTIONS

1. All board edges should be loosely abutted and never kicked in tight in typical installations. Please refer to the Typical Properties and Characteristics chart on page 1 to calculate the gap needed for your specific project (coefficient of thermal expansion and linear variation with change in moisture).
2. Install approved fasteners with plates into the USG SECUROCK Gypsum-Fiber Roof Board, flush with the surface. Fasteners should be installed in strict compliance with Mule-Hide's specifications and details.
3. Locate edge joints on, and parallel to, deck ribs. Stagger end joints of adjacent lengths of USG SECUROCK Gypsum-Fiber Roof Board.
4. Roof boards should never be installed when they are frozen.
5. See properties table for maximum flute span when panels are applied directly over metal decking.
6. For vertical parapet applications, only 1/2" or 5/8" panels should be used. Maximum framing spacing is 24" OC.
7. Panel spacing may be needed based on factors like roof deck's size, membrane color, ultimate deck surface temperature and time of year the roof is installed.

*Review Mule-Hide specifications and details for complete installation information.*

## PRECAUTIONS

- Consult Mule-Hide for specific instructions regarding the application of its products to USG SECUROCK Gypsum-Fiber Roof Board.
- For re-roof or re-cover applications, the existing roofing system must be dry throughout prior to application of USG SECUROCK Gypsum-Fiber Roof Board.
- When applying solvent-based adhesives or primers, allow sufficient time for the solvent to evaporate to avoid damage to roofing components.

# USG SECUROCK<sup>®</sup> Gypsum-Fiber Roof Board

**LEED INFORMATION**

Manufacturing Location	Pre-Consumer Recycled Content	Post-Consumer Recycled Content
Aliquippa, PA	97%	0%
Baltimore, MD	97%	0%
Bridgeport, AL	97%	0%
East Chicago, IL	97%	0%
Galena Park, TX	97%	0%
Jacksonville, FL	97%	0%
Norfolk, VA	97%	0%
Plaster City, CA	97%	0%
Rainier, OR	97%	0%
Shoals, IN	97%	0%
Sigurd, UT	97%	0%
Southard, OK	97%	0%
Sperry, IA	97%	0%
Sweetwater, TX	97%	0%
Washingtonville, PA	97%	0%

**PROTECTION & SAFETY**

Mule-Hide maintains Safety Data Sheets on all of its non-exempt products. Safety Data Sheets contain health and safety information for your development of appropriate product handling procedures to protect your employees and customers. Mule-Hide's Safety Data Sheets should be read and understood by all of your supervisory personnel and employees before using Mule-Hide products in your facilities.

**ADDITIONAL INFORMATION**

The information given on this PDS is subject to change without notice. Always check the Mule-Hide website at [www.mulehide.com](http://www.mulehide.com) for the latest information, changes and updates or contact Mule-Hide Products Company at 800-786-1492.

The trademarks SECUROCK<sup>®</sup>, the USG Logo<sup>™</sup> and related marks are trademarks of USG Corporation or its subsidiaries or affiliates.

**DISCLAIMER**

The statements provided concerning the material shown are intended as a guide for material usage and are believed to be true and accurate at the time of printing. No statement made by anyone may supersede this information, except when done in writing by Mule-Hide Products Co., Inc. Since the manner of use is beyond our control, Mule-Hide does not authorize anyone to make any warranty of merchantability or fitness for any particular purpose or any other warranty, guarantee or representation, expressed or implied, concerning this material. This product may be eligible for a Mule-Hide warranty, please check the Mule-Hide website at [www.mulehide.com](http://www.mulehide.com) or contact Mule-Hide directly at 800-786-1492 for details. Buyer and user accept the product under these conditions and assume the risk of any failure, any injury person or property (including that of the user), loss or liability resulting from the handling, storage or use of the product whether or not it is handled, stored or used in accordance with the directions or specifications. Mule-Hide must be notified in writing of any claims and be given the opportunity to inspect the alleged failure before repairs are made.



## Product Data Sheet

# MULE-HIDE ALL PURPOSE BAR

### **PRODUCT DESCRIPTION**

Rev. May 2020

All Purpose Bar is a specially extruded aluminum bar without sharp edges.

### **BASIC USES**

All Purpose Bar is designed for use as an anchor bar for attachment of the Mule-Hide EPDM membranes. The All Purpose Bar may be installed in the field seam as a batten bar and used at the base of curbs, parapet walls and angle changes as an anchor bar. The All Purpose Bar may also be used with any of the Mule-Hide single-ply membranes as a termination bar. Refer to the Mule-Hide Single-Ply Manuals for specific use and installation instructions.

### **SPECIFICATIONS**

Material:	Extruded Aluminum
Dimensions:	.050" thick x 1" wide x 10' long per piece.
Holes:	1/4" x 3/8" slotted holes on 6 inch centers.
Packaged:	50 pieces per tube
Approx. shipping weight:	40 lbs per tube
LEED Eligible Recycled Content	49%
Manufacturing Location	Cleveland, OH



### **INSTALLATION INSTRUCTIONS**

Position All Purpose Bar as per detail drawings (ribs facing outward or ribs facing inward)

When used as edge termination, ensure that water block sealant has been installed as per appropriate detail drawing, position bar with ribs facing substrate (to form sealant pocket) and attach with appropriate fastener into the substrate. When used for base attachment (see appropriate detail) position All Purpose Bar with ribs facing outward and attach with appropriate fastener into substrate.

### **PROTECTION & SAFETY**

Mule-Hide maintains Safety Data Sheets on all of its non-exempt products. Safety Data Sheets contain health and safety information for your development of appropriate product handling procedures to protect your employees and customers. Mule-Hide's Safety Data Sheets should be read and understood by all of your supervisory personnel and employees before using Mule-Hide products in your facilities.

### **ADDITIONAL INFORMATION**

The information given on this PDS is subject to change without notice. Always check the Mule-Hide website at [www.mulehide.com](http://www.mulehide.com) for the latest information & updates or contact Mule-Hide Products Company at 800-786-1492.

### **DISCLAIMER**

The statements provided concerning the material shown are intended as a guide for material usage and are believed to be true and accurate at the time of printing. No statement made by anyone may supersede this information, except when done in writing by Mule-Hide Products Co., Inc. Since the manner of use is beyond our control, Mule-Hide does not authorize anyone to make any warranty of merchantability or fitness for any particular purpose or any other warranty, guarantee or representation, expressed or implied, concerning this material. This product may be eligible for a Mule-Hide warranty, please check the Mule-Hide website at [www.mulehide.com](http://www.mulehide.com) or contact Mule-Hide directly at 800-786-1492 for details. Buyer and user accept the product under these conditions and assume the risk of any failure, any injury person or property (including that of the user), loss or liability resulting from the handling, storage or use of the product whether or not it is handled, stored or used in accordance with the directions or specifications. Mule-Hide must be notified in writing of any claims and be given the opportunity to inspect the alleged failure before repairs are made.





# Water Cut-Off Mastic

## Compression Sealant



### PRODUCT DATA SHEET



#### DESCRIPTION

Water Cut-Off Mastic is a one-part, low viscosity, self-wetting, butyl-blend mastic designed for sealing Mule-Hide membranes to wood, concrete, metal, plastic and other substrates. This product is an extremely tacky material and will remain so when used with a compression-type seal.

#### BASIC USES

Water Cut-Off Mastic can be used to seal roofing membranes to stop water penetration into the roofing system. Common uses are at drain terminations and behind Mule-Hide's All Purpose Bars at wall terminations.

#### BENEFITS AND SUPPLEMENTAL STATEMENTS

- Excellent adhesion to various substrates
- Provides a durable compression type seal
- Versatile applications

TYPICAL PROPERTIES AND CHARACTERISTICS*	
Color	Gray
Solids	80%
Flash Point	40°F (4°C) Closed Cup
Service Temperature	-40°F to 200°F (-40°C to 93°C)
Specific Gravity	1.29
Cold Weather Flexibility	Excellent
Average Brookfield Viscosity	1,320,000 cps

\*Typical properties and characteristics are based on samples tested and are not guaranteed for all samples of this product. This data and information is intended as a guide and does not reflect the specification or specification range for any particular property of this product.

LEED INFORMATION	
Pre-consumer Recycled Content	0%
Post-consumer Recycled Content	0%
Manufacturing Location	Carlisle, PA
VOC Content	250 g/L

#### PACKAGING

- (25) 11 oz tubes/carton. Weight per carton, 28 lbs.

#### COVERAGE RATES

- Approximately 10 lineal feet per using a ½" diameter bead.

#### SHELF LIFE

- 1 year (un-opened tube).

#### INSTALLATION INSTRUCTIONS

1. Mule-Hide Water Cut-Off Mastic is a one-component, ready-to-use material that requires no mixing or preparation.
2. Surface Preparation - Surfaces shall be dry, clean and free of all dust, or contamination, which may harmfully affect the adhesion of the sealant. Cleaning with appropriate cleaner, Weathered Membrane Cleaner (or PVC Membrane Cleaner may be required).
  - a. Weathered Membrane Cleaner for EPDM and TPO
  - b. PVC Membrane Cleaner for PVC
3. A quality caulking gun should be used to ensure ease of application.
4. Apply a ½" diameter bead of Mule-Hide Water Cut-Off Mastic between the substrate and the edge of the membrane. The membrane must cover the mastic.
5. Install appropriate termination detail and secure to provide constant compression for the Mule-Hide Water Cut-Off Mastic. Follow Mule-Hide's Specification Manual and Details for appropriate methods of termination.

#### CLEAN UP

- Clean Up - Excess Water Cut-Off Mastic can be removed with our Weathered Membrane Cleaner or PVC Membrane Cleaner. Water Cut-Off Mastic can also be removed from tools or equipment with our Weathered Membrane Cleaner or PVC Membrane Cleaner.



# Water Cut-Off Mastic

## Compression Sealant



### PRODUCT DATA SHEET

#### PRECAUTIONS

- See Material Safety Data Sheet for complete safety information before using product.
- Water Cut-Off Mastic is **FLAMMABLE** – contains solvents that area dangerous fire and explosion hazards when exposed to heat, flame or sparks. Store and use away from all sources of heat, flame or sparks. Do not smoke while applying. Do not use in a confined or unventilated area. Vapors are heavier than air and may travel along ground to a distant ignition source and flash back
- Avoid breathing vapors. Keep container closed when not in use. Use with adequate ventilation. If inhaled, remove to fresh air. If not breathing, perform artificial respiration. If breathing is difficult, give oxygen. Call a physician immediately.
- If swallowed, **DO NOT INDUCE VOMITING**. Call a physician immediately.
- Avoid contact with eyes. Safety glasses or goggles are recommended. If splashed in eyes, immediately flush eyes with plenty of clean water for at least 15 minutes. Contact a physician immediately.
- Avoid contact with skin. Wash hands thoroughly after handling. In case of contact with skin, thoroughly wash affected area with soap and water.

Note: Permeation-resistant gloves (that meet ANSI/ISEA 105-2005) are recommended to be worn when using this product to protect hands from irritating ingredients.

#### PROTECTION & SAFETY

Mule-Hide maintains Safety Data Sheets on all of its non-exempt products. Safety Data Sheets contain health and safety information for your development of appropriate product handling procedures to protect your employees and customers. Mule-Hide's Safety Data Sheets should be read and understood by all of your supervisory personnel and employees before using Mule-Hide products in your facilities.

#### ADDITIONAL INFORMATION

On projects where a Mule-Hide Standard or Premium Warranty is requested, an authorized Mule-hide representative shall inspect all completed work.

The information given on this PDS is subject to change without notice. Always check the Mule-Hide website at [www.mulehide.com](http://www.mulehide.com) for the latest information, changes and updates or contact Mule-Hide Products Company at 800-786-1492.

#### DISCLAIMER

The statements provided concerning the material shown are intended as a guide for material usage and are believed to be true and accurate at the time of printing. No statement made by anyone may supersede this information, except when done in writing by Mule-Hide Products Co., Inc. Since the manner of use is beyond our control, Mule-Hide does not authorize anyone to make any warranty of merchantability or fitness for any particular purpose or any other warranty, guarantee or representation, expressed or implied, concerning this material. This product may be eligible for a Mule-Hide warranty, please check the Mule-Hide website at [www.mulehide.com](http://www.mulehide.com) or contact Mule-Hide directly at 800-786-1492 for details. Buyer and user accept the product under these conditions and assume the risk of any failure, any injury person or property (including that of the user), loss or liability resulting from the handling, storage or use of the product whether or not it is handled, stored or used in accordance with the directions or specifications. Mule-Hide must be notified in writing of any claims and be given the opportunity to inspect the alleged failure before repairs are made



## Product Data Sheet

# BLACK LAP SEALANT

### DESCRIPTION

Revision Date: June 2024

Mule-Hide's Sure-Seal Lap Sealant is a gun-consistency material used to seal the exposed cut edge of reinforced EPDM membranes, and the edges of un-cured flashing. Mule-Hide's Lap Sealants are extremely durable, and their cured rubber consistency enables them to expand and contract with the roofing membrane.

### FEATURES AND BENEFITS

- Seals exposed cut edge of reinforced EPDM membranes and the edges of un-cured flashing.
- Cured rubber consistency
- Applied using a caulk gun
- Seals EPDM edge splices

### COVERAGE RATE

This material has a coverage rate of 22' (6.7 m) per tube using a 5/16" (8 mm) bead



### INSTALLATION

1. All surfaces to be sealed with Lap Sealant must be firm, dry, and free of oil, dust, and other foreign materials.
2. After splices are completed with the proper splicing materials, clean the EPDM to remove all foreign materials by wiping with a clean rag dampened with Weathered Membrane Cleaner.

Note: Permeation resistant gloves (that meet ANSI/ISEA 105-2005) are recommended while using this material.

3. Apply a 5/16" (8 mm) bead of Lap Sealant along the exposed edge of the membrane.
4. Lap Sealant must be applied on any required un-cured flashing edges by the end of the working day. Lap sealant may be applied immediately to the un-cured flashing.

*Review Mule-Hide specifications and details for complete installation information.*

### PRECAUTIONS

- Review the applicable Safety Data Sheet for complete safety information prior to use.
- Lap Sealants are **FLAMMABLE**. They contain petroleum distillates that are dangerous fire and explosion hazards when exposed to heat, flame or sparks. Store and use away from all sources of heat, flame or sparks. Do not smoke while applying. Do not use in confined or unventilated areas. Vapors are heavier than air and may travel along the ground to a distant ignition source and flash back. A red caution label is required for shipping.
- Avoid breathing vapors. Keep container closed when not in use. Use with adequate ventilation. If inhaled, remove to fresh air. If not breathing, perform artificial respiration. If breathing is difficult, give oxygen. Call a physician immediately.
- If swallowed, **DO NOT INDUCE VOMITING**. Call a physician immediately.
- Avoid contact with eyes. Safety glasses or goggles are recommended. If contact with eyes occurs, immediately flush eyes with plenty of water for at least 15 minutes. Contact a physician immediately.
- Avoid contact with skin. Wash hands thoroughly after handling. In case of contact with skin, thoroughly wash affected area with soap and water.
- Follow Mule-Hide's recommended splice instructions. **DO NOT USE** as splice cement between membranes.

# Product Data Sheet

## BLACK LAP SEALANT

- Jobsite storage temperatures in excess of 90°F (32°C) will shorten product shelf life. Should the Lap Sealant be stored at temperatures below 60°F (15°C), restore to room temperature prior to use.
- By using an excessively wet solvent cloth while cleaning the splice edge, solvent may be left in the offset of the membrane sheets. To avoid this problem, use a damp rag and make sure the Weathered Membrane Cleaner is completely flashed off before Lap Sealant application.
- If applied during periods of cold, dampness or high humidity, it is possible that the evaporation of solvents will be substantially reduced, resulting in some slight membrane swelling. This would be further aggravated should the sealant be applied in an unusually heavy coat.
- Coverage rates are average and may vary due to jobsite conditions.
- KEEP OUT OF THE REACH OF CHILDREN.

### **TYPICAL PHYSICAL PROPERTIES**

Color	Black
Solids	63%
Flash Point	40°F (4°C) Tag Open Cup
Service Temperature	-60°F to 180°F (-51°C to 82°C)
Specific Gravity	1.03
Cold Weather Flex	Excellent
Resistance to: Staining	
General Weathering	Excellent
Ozone	Excellent
Ultraviolet Radiation Slump	Excellent
Water	Excellent
Acid	Very Good
Alkali	Excellent
	Good
	Good
VOC	400 grams/liter
Average Net Weight/Gallon	8.58 lbs. (1.03 Kg/l)
Packaging	25 Tubes/Carton
Shelf Life	1 year

### **LEED® INFORMATION**

Pre-consumer Recycled Content	0%
Post-consumer Recycled Content	0%
Manufacturing Location	Carlisle, PA

### **PROTECTION & SAFETY**

Mule-Hide maintains Safety Data Sheets on all of its non-exempt products. Safety Data Sheets contain health and safety information for your development of appropriate product handling procedures to protect your employees and customers. Mule-Hide's Safety Data Sheets should be read and understood by all of your supervisory personnel and employees before using Mule-Hide products in your facilities.

### **ADDITIONAL INFORMATION**

The information given on this PDS is subject to change without notice. Always check the Mule-Hide website at [www.mulehide.com](http://www.mulehide.com) for the latest information, changes and updates or contact Mule-Hide Products Company at 800-786-1492.

# BLACK LAP SEALANT

---

## **DISCLAIMER**

The statements provided concerning the material shown are intended as a guide for material usage and are believed to be true and accurate at the time of printing. No statement made by anyone may supersede this information, except when done in writing by Mule-Hide Products Co., Inc. Since the manner of use is beyond our control, Mule-Hide does not authorize anyone to make any warranty of merchantability or fitness for any particular purpose or any other warranty, guarantee or representation, expressed or implied, concerning this material. This product may be eligible for a Mule-Hide warranty, please check the Mule-Hide website at [www.mulehide.com](http://www.mulehide.com) or contact Mule-Hide directly at 800-786-1492 for details. Buyer and user accept the product under these conditions and assume the risk of any failure, any injury person or property (including that of the user), loss or liability resulting from the handling, storage or use of the product whether or not it is handled, stored or used in accordance with the directions or specifications. Mule-Hide must be notified in writing of any claims and be given the opportunity to inspect the alleged failure before repairs are made.



# Product Data Sheet

## MULE-HIDE BLACK ONE-PART POURABLE SEALER

### PRODUCT DESCRIPTION

Black One-Part Pourable Sealer is a one-part, moisture curing, elastomeric polyether sealant providing rapid skin time when exposed to atmospheric moisture forming a waterproof rubber surface in less than an hour. Moisture curing continues for fourteen to twenty-eight days, until a two-inch deep solid rubber seal encases the penetration. Complete cure time will vary depending on relative humidity and temperature. Mule-Hide's Tape Primer must be applied to all surfaces that will be in contact with the Black One-Part Pourable Sealer. Unused sealant remaining in the pouch will remain useable up to 30 days if pouch is resealed with original cap.



### BASIC USES

This product is designed for use with our EPDM Sealant Pockets. The sealant's one-part, pourable consistency allows for quick pocket filling without mixing

### SPECIFICATIONS

Typical Values*	
Color	Black
Odor	Mild ester smell (mint) when wet. Odorless when dry.
Specific Gravity	1.4 (11.6 lbs/gallon) – 1.5 (12.5 lbs/gallon)
Viscosity (Brookfield RTV), cps	Self leveling 20,000 – 50,000
Hardness (Shore A) ASTM C 0661	25 - 35
Tack Free Time ASTM C 0679	Less than 1 hour @ 70 degrees F. (21 degrees C)
Low temperature flex – PASS	Minus 20 degrees F
Service Temperature ASTM 2453	Minus 40 degrees F to 200 degrees F. (Minus 40 degrees C to 93 degrees C)
Shrinkage (14 day cure)	No measurable shrinkage
Elongation @ Break, % ASTM D 412	450
Long Term Weatherability ASTM G 53 - 98 cycles @ 12 hours/cycle - Condensate exposure: 4 hrs @ 122°F (50°C) - U.V. exposure – 8 hrs@ 158°F (70°C)	No Cracking or crazing
*Typical properties and characteristics are based on samples tested and are not guaranteed for all samples of this product. This data and information is intended as a guide and does not reflect the specification or specification range for any particular property of this product.	

### PACKAGING

Each carton contains: 4 – 0.5 Gallon pouches per bucket (4-2 liter)  
Weight Per Carton: 29 lbs/bucket (13.15 kg)

### BENEFITS & SUPPLEMENTAL STATEMENTS

- No mixing required – ready to use
- Resealable pouch using original cap
- Provides a flexible and long-lasting seal around hard to flash projections
- Provides a watertight seal in less than one hour after application





# Product Data Sheet

## MULE-HIDE BLACK ONE-PART POURABLE SEALER

### COVERAGE RATES

One 0.5-gallon pouch (2-liter) will fill 122 cubic inches of volume within a sealant pocket. As an example, one 6" EPDM Sealant Pocket will require 0.23 gallons (0.87 liters) to fill completely (with no penetrations). Coverage rates are average and may vary due to job site conditions.

### INSTALLATION INSTRUCTIONS\*

#### Preparation

1. Surfaces must be free of moisture, dirt and any contaminants. Any previously applied asphalt, caulking or sealants must be removed from the penetration.
2. Fill any voids in the roof deck around the penetration(s) to prevent sealant from seeping through the roof. Pourable sealer must be a minimum of 2" (50 mm) deep. All penetrations must be a minimum of 1" (25 mm) from the sides of the pitch pan or sealer pocket.
3. Clean all surfaces with Weathered Membrane Cleaner.
4. Mule-Hide Tape Primer is required for prepping all EPDM surfaces, including the cured deck membrane and the interior surfaces of the pocket that will be in contact with the pourable sealer. DO NOT apply primer to blue plastic strip that forms inside wall of pourable sealer pocket. Allow primer to dry.
5. Remove cap from 0.5-gallon (2-liter) pouch and pour Black One-Part Pourable Sealer directly into pocket. Fill pocket completely until rim is covered with Black One-Part Pourable Sealer making sure all voids are filled.
6. To save unused sealant, squeeze air from pouch and replace cap. Unused sealant should be used within 30 days.
7. For results maintain this product at room temperature before use.
8. For cold weather applications remove any frost or moisture from inside pocket using a hand held heat gun.

\*Review current Mule-Hide Specifications and Details for specific application requirements.

#### Precautions

1. Review the applicable Material Safety Data Sheet for complete safety information prior to use.
2. Avoid breathing vapors. Keep container closed when not in use. Use with adequate ventilation. If inhaled, remove to fresh air. If not breathing, perform artificial respiration. If breathing is difficult, give oxygen. Call a physician immediately.
3. If swallowed, DO NOT INDUCE VOMITING! Call a physician immediately.
4. Avoid contact with eyes. Safety glasses or goggles are recommended. If splashed in eyes, immediately flush eyes with water for at least 15 minutes. Contact a physician immediately.
5. Avoid contact with skin. Wash hand thoroughly after handling. In case of contact with skin, thoroughly wash affected area with soap and water.
6. Do not thin. Thinning will affect performance.
7. Avoid contact with non-rubber surfaces as staining will result.
8. KEEP OUT OF REACH OF CHILDREN.

### LEED® INFORMATION

Pre-consumer Recycled Content	0%
Post-consumer Recycled Content	0%
VOC Content	<25g/L
Manufacturing Location	Schoolcraft, MI

### STORAGE & HANDLING

Shelf life is established at 18 months. Shelf life is based on storage in original, unopened or undamaged





# Product Data Sheet

## MULE-HIDE BLACK ONE-PART POURABLE SEALER

containers at temperatures ranging from 60°F to 80°F. Should the Pourable Sealer be exposed to lower temperatures, restore to room temperature prior to use.

### **PROTECTION & SAFETY**

Mule-Hide maintains Safety Data Sheets on all of its non-exempt products. Safety Data Sheets contain health and safety information for your development of appropriate product handling procedures to protect your employees and customers. Mule-Hide's Safety Data Sheets should be read and understood by all of your supervisory personnel and employees before using Mule-Hide products in your facilities.

### **ADDITIONAL INFORMATION**

The information given on this PDS is subject to change without notice. Always check the Mule-Hide website at [www.mulehide.com](http://www.mulehide.com) for the latest information, changes and updates or contact Mule-Hide Products Company at 800-786-1492.

### **DISCLAIMER**

The statements provided concerning the material shown are intended as a guide for material usage and are believed to be true and accurate at the time of printing. No statement made by anyone may supersede this information, except when done in writing by Mule-Hide Products Co., Inc. Since the manner of use is beyond our control, Mule-Hide does not authorize anyone to make any warranty of merchantability or fitness for any particular purpose or any other warranty, guarantee or representation, expressed or implied, concerning this material. This product may be eligible for a Mule-Hide warranty, please check the Mule-Hide website at [www.mulehide.com](http://www.mulehide.com) or contact Mule-Hide directly at 800-786-1492 for details. Buyer and user accept the product under these conditions and assume the risk of any failure, any injury person or property (including that of the user), loss or liability resulting from the handling, storage or use of the product whether or not it is handled, stored or used in accordance with the directions or specifications. Mule-Hide must be notified in writing of any claims and be given the opportunity to inspect the alleged failure before repairs are made.



# Product Data Sheet

## MULE-HIDE UNCURED SEALER POCKETS

### PRODUCT DESCRIPTION

Mule-Hide Pourable Sealer Pockets are prefabricated pockets consisting of a 2" (50 mm) wide plastic support strip with attached Uncured EPDM Flashing Tape.

### BASIC USES

Mule-Hide's Pourable Sealer Pockets are ideal for sealing irregular, hard to flash penetrations through the membrane.

### BENEFITS & SUPPLEMENTAL STATEMENTS

- Available in 4" (100 mm), 6" (150 mm) and 8" (200 mm) diameters
- Pockets can be combined to create larger pockets as needed
- Pockets can be stacked two high to create taller pockets

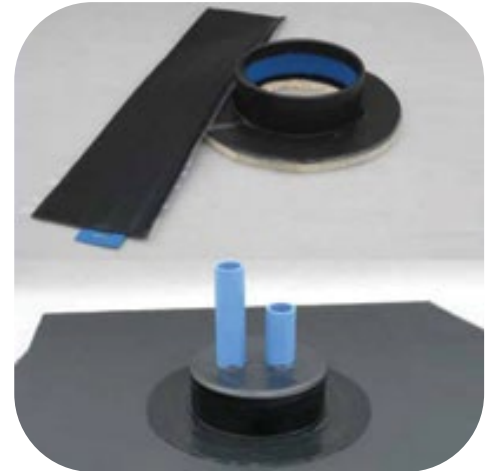

### SPECIFICATIONS

Color:	Black
Size / Weight:	4" – 12 per carton - 5 lbs (2.25 kg) 6" – 12 per carton – 7 lbs (3.2 kg) 8" – 12 per carton – 9 lbs (4.1 kg)
Shelf Life:	Nine (9) months when stored between 60°F - 80°F (15°C - 26°C)
Typical properties and characteristics are based on samples tested and are not guaranteed for all samples of this product. This data and information is intended as a guide and does not reflect the specification or specification range for any particular property of this product.	

### INSTALLATION INSTRUCTIONS

1. Clean all mating surfaces with Weathered Membrane Cleaner and allow to dry. **Prime** all surfaces that will contact Pourable Sealer with Tape Primer, including deck membrane, penetration and uncured flashing. Primer should NOT be applied to blue plastic strip that forms inside wall of sealer pocket.
2. Remove the colored poly from the flashing side of the pocket and save for later. Then remove the clear poly from the blue support ring (plastic strip). Place the clear poly on the flashing side and fold in half with blue support ring on outside.
3. Join the two tabs by inserting the tab into the slot. Tab should be on the inside of the pocket. A more uniform circular shape can be accomplished by rolling the assemble pocket in your hands. Remove the clear poly from the flange of the pocket.
4. Position the sealer pocket to achieve a minimum 1" clearance from the penetration to the side of the pocket.
5. Starting at the overlap, form the flange to the deck membrane. Continue forming the flange and stop approximately half way around the pocket.
6. To complete the vertical splice of the sealer pocket, remove the clear poly and apply tape primer to the splice area. Allow the primer to flash off. Set the top edge and roll the flashing into the angle change. Next, roll the flashing down onto the deck without stretching. Pull the corner of the flange to achieve a minimum 3" wide deck splice.
7. Roll the top of the flashing down inside the pocket. Roll the detail with a 2" roller, paying attention to the angle change.
8. Prime all surfaces that will be in contact with the pourable sealer, including the inside of the pocket and projection with tape primer. After the primer has flashed, fill the pocket with pourable sealer.



# Product Data Sheet

## MULE-HIDE UNCURED SEALER POCKETS

### **INSTALLATION INSTRUCTIONS (Continued)**

9. Completely fill the pocket and crown the top surface to prevent ponding water. But be sure not to overfill or allow pourable sealer to overflow the pocket. If the pourable sealer overflows the pocket, it must be cleaned up.
10. Pourable sealer must be a minimum of 2" deep.
11. Do not use where the maximum temperature will exceed 180°F (82°C).

### **STORAGE & HANDLING**

Normal shelf life is nine (9) months when stored between 60°F and 80°F (15°C to 26°C). Job site storage temperature over 90°F (32°C) may affect product shelf life.

### **LEED® INFORMATION**

Pre-consumer Recycled Content	2%
Post-consumer Recycled Content	0%
Manufacturing Location	Greenville, IL
Solar Reflectance Index (SRI)	N/A

### **PROTECTION & SAFETY**

Mule-Hide maintains Safety Data Sheets on all of its non-exempt products. Safety Data Sheets contain health and safety information for your development of appropriate product handling procedures to protect your employees and customers. Mule-Hide's Safety Data Sheets should be read and understood by all of your supervisory personnel and employees before using Mule-Hide products in your facilities.

### **ADDITIONAL INFORMATION**

The information given on this PDS is subject to change without notice. Always check the Mule-Hide website at [www.mulehide.com](http://www.mulehide.com) for the latest information, changes and updates or contact Mule-Hide Products Company at 800-786-1492.

### **DISCLAIMER**

The statements provided concerning the material shown are intended as a guide for material usage and are believed to be true and accurate at the time of printing. No statement made by anyone may supersede this information, except when done in writing by Mule-Hide Products Co., Inc. Since the manner of use is beyond our control, Mule-Hide does not authorize anyone to make any warranty of merchantability or fitness for any particular purpose or any other warranty, guarantee or representation, expressed or implied, concerning this material. This product may be eligible for a Mule-Hide warranty, please check the Mule-Hide website at [www.mulehide.com](http://www.mulehide.com) or contact Mule-Hide directly at 800-786-1492 for details. Buyer and user accept the product under these conditions and assume the risk of any failure, any injury person or property (including that of the user), loss or liability resulting from the handling, storage or use of the product whether or not it is handled, stored or used in accordance with the directions or specifications. Mule-Hide must be notified in writing of any claims and be given the opportunity to inspect the alleged failure before repairs are made.



# SUMMARY SPECIFICATION

## EPDM – MECHANICALLY ATTACHED ROOFING SYSTEM

Revision Date: May 13, 2019

This Summary Specification is a brief overview of Mule-Hide Product's specification and requirements for a Mechanically Attached Mule-Hide Reinforced EPDM Roofing System and is intended for use as a submittal in a bid package. Specifier's and Mule-Hide Warranty Eligible Applicators must comply with Mule-Hide Product's specifications and requirements prior to design or bid.

### Part 1 General

#### 1.01 Description

The Mule-Hide Mechanically Attached Reinforced EPDM Roofing System utilizes a (maximum) 10' wide, reinforced Mule-Hide EPDM membrane in thickness of 45, 60 or 75-mil. Approved insulation is attached to the substrate with either Mule-Hide Insulation fasteners and plates or Mule-Hide Helix® Max low-rise foam adhesives. The EPDM membrane is attached to the substrate with System Fasteners and Plates. Adjoining sheets are overlapped approximately 6" and seamed together with tape primer and 6" in-seam tape.

#### 1.02 Quality Assurance

- A. The roofing system must be installed by a Mule-Hide Warranty Eligible Applicator in accordance with installation guidelines and detail drawings as approved by Mule-Hide. Prior written approval from the Mule-Hide Warranty Department is required for all deviations from Mule-Hide's published specifications and details.
- B. Projects requesting a Labor and Material Warranty will be inspected by a Mule-Hide Representative to verify that Mule-Hide's installation and material requirements have been met.
- C. Mule-Hide roofing systems offer a variety of Underwriters Laboratories (UL), Factory Mutual (FM) and other ratings. Consult the appropriate approval guides and Mule-Hide Products for specific code approvals.

#### 1.03 Submittals

- A. To ensure compliance with Mule-Hide's warranty requirements contact the Mule-Hide Warranty Department if any of the following conditions exist.
  1. Specified wind speed warranty greater than 55 MPH.
  2. Building height > 50'
  3. Projects located in coastal or high wind zones.
  4. Pressurized buildings
  5. Cold Storage or Freezer Buildings
  6. Membrane exposed to chemicals

- B. Submit a completed Warranty Application form to Mule-Hide prior to bidding. Also include fastener pullout testing results as required for non-standard substrates.
- C. All projects must have a Mule-Hide warranty application number assigned prior to inspection.

#### 1.04 Product Delivery, Storage, and Handling

- A. Deliver materials to the job site in original, unopened containers, with the manufacturer's name, brand name and installation instructions.
- B. Store all materials in a dry, clean area protected from the elements, as per manufacturer's recommendations.

#### 1.05 Job Conditions

- A. All existing wet or damaged roofing materials must be removed and replaced with new mat'ls.
- B. All existing phenolic insulation and sprayed-in-place urethane roofs must be removed.
- C. The specifier must determine the use and placement of vapor retarders. Consult ASHRAE (American Society of Heating, Refrigerating, and Air-Conditioning Engineers, Inc.) and NRCA (National Roofing Contractors Association) publications.
- E. Coordinate work between all trades to avoid traffic over completed sections of roofing.

#### 1.06 Warranty.

Fees are required for all Labor and Material (System) Warranties. System Warranties must be obtained through a Mule-Hide Warranty Eligible Applicator. All projects requesting a System Warranty must be inspected by a Mule-Hide Representative. Components of the roofing system must be supplied by Mule-Hide. Warranty covers only Mule-Hide supplied materials. Sample warranties are available upon request. Contact Mule-Hide Warranty Department for warranty requirements.

### Part 2 Products

#### 2.01 General

The components of this roofing system are to be manufactured, supplied, or approved in writing by Mule-Hide Products.

# Summary Specification

## EPDM – Mechanically Attached Summary Specification

### 2.02 Membrane

Mule-Hide White reinforced 45, 60 or 75-mil thick EPDM membrane is used for this system. The membrane is available in widths up to 10' and in lengths of up to 100'. Refer to our Product Data Sheet for physical properties and other information.

### 2.03 Related Materials

Mule-Hide products include: Cured and uncured Flashings, Bonding Adhesives, EPDM Lap Sealant, Membrane fasteners and discs, Pourable Sealer, All-Purpose Bar, EPDM Walkway Pads, Universal Single Ply Sealant, and other components.

## Part 3 Execution

### 3.01 General

- A. Work should begin at the highest point of the roof level and proceed to the lowest point. Work should be completed on a daily bases including flashings, terminations, and daily seals.
- B. Prepare the existing roof deck or substrate according to Mule-Hide design guides and full-system specifications prior to applying the new roofing system.

### 3.02 Roof Deck Criteria

- A. A proper substrate shall be provided by the building owner. The structure shall be able to withstand normal construction loads and live loads.
- B. Substrate must allow for drainage so that all water is removed within 48 hours after a rain.

### 3.03 Substrate Preparation

- A. Re-cover projects - All wet or damaged materials must be removed and replaced with new materials.
- B. Substrate must be clean, level, and smooth so that the insulation lays flat. Fresh applications of bitumen based roof cement must be removed or covered.

### 3.04 Installation

Refer to the applicable Product Data Sheets and Safety Data Sheets for cautions and warnings.

#### A. Insulation Attachment

Attach roof insulation with Manufacturer supplied roofing fasteners and plates or low-rise foam adhesive. Attachment rates will vary depending upon type and size of insulation board installed. Consult Mule-Hide Warranty Department for attachment requirements.

#### B. Membrane Installation and Seaming

Place membrane over substrate with minimum 6" overlap at lap seams and positioned so that laps will shed water. Allow membrane to relax. After membrane has relaxed, fold membrane back to expose underlying sheet. Install System Fasteners and Plates along seam edge. Sheet width, as well as spacing of Fasteners and plates will vary depending upon wind uplift requirements. Fold sheet back and seam with tape primer and 6" in-seam tape. Consult Mule-Hide Warranty Department for attachment requirements.

#### C. Additional Membrane Securement

The membrane must be secured at the perimeter of each individual roof area, projection, and any angle change that exceeds 2" per lineal foot. Consult Mule-Hide's published detail drawings.

#### D. Membrane Flashing

All existing base flashings are to be removed. Install new membrane flashings as per manufactures details and guidelines. Flashings must be terminated along top edge as per appropriate Mule-Hide detail.

#### E. Other Related Work

1. Walkways should be provided in areas where regular rooftop traffic is expected. Walkways are considered a maintenance item and are excluded from the Mule-Hide warranty.
2. Mule-Hide EPDM Pads are to be installed over clean, dry surfaces, with a minimum 6" spacing over field seams. The Walkway Pad is adhered to the field membrane with pre-applied seam tape.
3. Concrete pavers may be used if installed over one layer of HP Protection Mat.
4. Copings, counter flashing and other metal work shall be fastened to resist wind uplift and prevent buckling. Metal should be sealed to prevent moisture infiltration.

This summary specification represents the applicable information available at time of publication. Mule-Hide reserves the right to change this information at any time. Contact Mule-Hide Products or visit our website at [www.mulehide.com](http://www.mulehide.com) for the latest updates, changes, or modifications to this summary specification.



**MULE-HIDE PRODUCTS CO., INC.**  
**PREMIUM SINGLE-PLY NDL SYSTEM WARRANTY FOR COMMERCIAL BUILDINGS** Ver.4.5

Serial Number:

Building Owner:

Building Address:

**SAMPLE**

Effective Date:

Expiration Date:

In consideration of the warranty fee paid by or on behalf of the above-named Building Owner ("Owner") and the representations to Mule-Hide Products Co., Inc. ("Mule-Hide") by the independent contractor hired by the Owner and registered with Mule-Hide as eligible to apply for warranties ("Eligible Contractor") that the Mule-Hide Roofing System ("System") has been constructed in accordance with Mule-Hide specifications, Mule-Hide warrants to Owner, subject to the following Terms, Conditions and Limitations, that Mule-Hide will be responsible for the repair of leaks in the System installed on the Building for the warranty period indicated above, however, that the System shall have been installed by Eligible Contractor using Mule-Hide products and/or other materials supplied or approved in writing by Mule-Hide. "System" for purposes of this Warranty is defined as the following Mule-Hide brand materials: Single-ply Membrane and Flashing Accessories, Adhesives and Sealants, Insulation, Fasteners, Fastener Plates, Fastening/Termination Bar, Metal Edging/Coping, any other Mule-Hide brand products or other components supplied or approved by Mule-Hide and shall exclude the roof deck, wood nailers, pre-existing roof system to which the new system is applied or covers, support system, and metal flashings (non-Mule-Hide approved or supplied) and any components of the roofing assembly not supplied or approved in writing by Mule-Hide. The watertight integrity of walls, parapet walls and other adjacent structures is not covered. The paint finish on any Mule-Hide labeled metal product that is part of the System is not covered by this Warranty. Metal finish warranties can be obtained by contacting Mule-Hide directly. There is no dollar limitation (NDL) on covered repairs. Any dispute, controversy or claim between Owner and Mule-Hide arising out of or related to this Warranty or the Building shall be settled by final and binding arbitration in accordance with the rules of the American Arbitration Association for the Construction Industry. By accepting this Warranty, Owner represents that the Building is a commercial structure and is not used for owner's personal or household purposes. In consideration of the protection afforded by this Warranty, Owner accepts the following Terms, Conditions and Limitations:

1. Within thirty (30) days after Owner or any of its agents discovers (or a reasonable person in Owner's or agent's position would have discovered) any leak, Owner must give written notice (the "Notice") to Mule-Hide Warranty Claims (notice to the contractor, a re-seller or an authorized Mule-Hide Sales Representative is not notice to Mule-Hide Warranty Claims) of the existence of each leak in the System or Mule-Hide will have no responsibility for the repairs.
2. Mule-Hide shall have the right to inspect the System after receiving the Notice to determine the cause(s) of the leak before incurring any obligation hereunder. In the event the cause of the leak is not covered by the Warranty, Owner will pay to Mule-Hide a reinspection fee and expenses (in accordance with Mule-Hide's standard charges) promptly after Mule-Hide issues an invoice for same. If, upon Mule-Hide's inspection, Mule-Hide determines that the leaks in the system are caused by defects in Mule-Hide's materials or workmanship of the Contractor, Owner's remedies and Mule-Hide's liability shall be limited to Mule-Hide's repair of the portion of the System determined to be leaking using methods determined to be suitable at Mule-Hide's discretion. In no event shall Mule-Hide be obligated to perform additional services (e.g. roof drains, equipment relocation, old roof removal, etc.) or provide materials or services beyond the scope of the Owner's original contract with Contractor.
3. This warranty may be transferred provided the original owner follows the Mule-Hide Warranty Transfer Procedure. Contact Mule-Hide Technical Department at 1-800-786-1492 for a copy of the procedure.
4. If the System is damaged by any of the following causes, this Warranty shall not apply to such damages:
  - (a) Any natural cause, including but not limited to lightning, the infestation or presence of plant, mold, fungi, bacteria, insects or an animal, or earthquake, peak gust wind speeds in excess of 55 mph, hurricane, tornado, hail greater than 0 inches in diameter (as reported by the National Climatic Data Center), or any debris resulting from any of these causes. Mule-Hide shall not be responsible for any changes in appearance or surface imperfections caused by hail events.
  - (b) Acts of negligence, accident, misuse or abuse, including but not limited to vandalism, fire, falling object, civil disobedience, or acts of war.
  - (c) The use in the System of metal work, coping, counter-flashing, rain-carrying components or other material not furnished or otherwise approved in writing by Mule-Hide.
  - (d) Environmental fallout, chemical attack, use of products or materials incompatible with the System or the presence within or outside the Building of any commercial or industrial solvent, acid, caustic fluid, petroleum product, wax, grease, absorbent, clay or plasticizer.
  - (e) Negligence of a contractor who is not the Eligible Contractor, or failure of the material or the workmanship provided by such a contractor.
  - (f) Interior condensation and any resulting damage or condition, including but not limited to, mold, fungi or bacteria.
  - (g) The infiltration of moisture in, through or around the building through any mechanism other than through the System, including but not limited to, any structural defect, wall, or other Building structure, or anything that penetrates the System, including but not limited to any vent, coping or rooftop equipment and any resulting damage or condition, including but not limited to, mold, fungi or bacteria.
  - (h) Any deterioration, failure, settlement or movement of building components, including but not limited to the roof structure, roof substrate (pre-existing roof system or retained components), roof deck, wood nailers, walls, mortar, HVAC units, skylights, etc. or the expansion or contraction of any counterflashing or metal work.
  - (i) Defects in the building, pre-existing conditions or roof design, including but not limited to any conditions that prevent positive drainage.
5. Mule-Hide may, in its discretion, suspend or cancel this warranty if the roof is damaged by any cause listed above as an exclusion from coverage that may affect the integrity of the roof tightness of the roof.
6. Occurrence of any of the following shall render the Warranty cancelable in Mule-Hide's sole discretion and terminate obligations under this Warranty:
  - (a) Alteration or repair made on or through the roof without prior written authorization from Mule-Hide.
  - (b) Placement upon or attachment to the roof of any object (including but not limited to any structure, fixture or utility) without prior written authorization from Mule-Hide.
  - (c) Owner's or the Building occupant's failure to use reasonable care in maintaining the roof including, but not limited to, items listed on the reverse side of this document titled "Mule-Hide Owner's Care and Maintenance Information".
  - (d) Internal positive pressure condition which causes or contributes to a partial or total failure of the roof.
  - (e) Owner's sale of the Building or purported assignment of this Warranty, except as provided in (3), above.
  - (f) Owner's failure to comply with every Term, Condition and Limitation in this Warranty.
7. Mule-Hide, its agents, employees and contractors shall have unrestricted access to the roof during regular business hours. By accepting this Warranty, Owner agrees to arrange for removal of water, snow, ice, equipment, any paving or overburden at Owner's expense to allow for investigation or repairs to be made. The Owner is responsible to provide safe access to the roof.
8. All bills for installation, supplies and services shall have been paid in full to Eligible Contractor and all material suppliers before Mule-Hide incurs any obligation or liability under this Warranty. It is the Owner's sole responsibility to confirm that payment has been made to Eligible Contractor and all material suppliers.
9. The failure of Mule-Hide at any time to assert or enforce any Term, Condition and Limitation shall not be construed to be a waiver thereof, or of any other Term, Condition or Limitation. Unless otherwise agreed in advance and in writing, any inspections made by Mule-Hide are limited to a surface inspection only. All inspections are for Mule-Hide's sole benefit, and do not constitute a waiver of any terms and conditions herein.
10. Any and all other express warranties are superseded hereby and this Warranty is in lieu thereof.
11. Owner acknowledges that the Eligible Contractor is not an agent or other legal representative of Mule-Hide. Mule-Hide is not liable for any promise, representation or other responsibility of Eligible Contractor or any other party. This warranty is not binding upon Mule-Hide unless executed by an executive officer of Mule-Hide or a duly authorized employee of Mule-Hide's Warranty Department. No representative or employee of Mule-Hide, or any other party, may alter this Warranty without the prior written consent of an executive officer of Mule-Hide. This Warranty constitutes the entire understanding of the parties with respect to the subject matter contained herein, and revokes and supersedes all prior agreements, whether written or oral, between the parties. This Warranty shall take precedence over any other documents or representations (whether oral or written, and by whomever made) which may conflict with this Warranty.
12. The predominant factor in the construction and performance of the System is the design and construction services of the contractor and not the sale of goods. In addition, Owner acknowledges that Owner had a duty hereunder to exercise reasonable care in the selection of a contractor.
13. Mule-Hide is not liable for the cleanliness or discoloration of the System caused by environmental conditions including but not limited to dirt, pollutants or any biological agent.

MULE-HIDE DOES NOT WARRANT PRODUCTS UTILIZED IN THIS INSTALLATION WHICH IT HAS NOT FURNISHED; AND SPECIFICALLY DISCLAIMS LIABILITY, UNDER ANY THEORY OF LAW, ARISING OUT OF THE INSTALLATION AND PERFORMANCE OF, OR, DAMAGES SUSTAINED BY OR CAUSED BY, PRODUCTS NOT FURNISHED BY MULE-HIDE.

## **Building Owner's Roof Care and Maintenance Guidelines ver.2.03**

Following are guidelines on how to care for your roofing system to help ensure a long useful service life. The manufacturer's warranty is not a maintenance program or agreement. There are various items associated with your roof system that are not covered under the warranty. It is the responsibility of the Building Owner to regularly inspect and maintain their roofing system.

Mule-Hide strongly recommends the Building Owner institutes an annual inspection program with written documentation of any activities on the roof. Maintain a log of maintenance procedures and people accessing the roof. This aids the Building Owner in determining the source of any damage to the roof. The roofing system should be inspected at least twice a year (once in the spring and once in the fall) and after every major storm. These inspections should be performed by a Mule-Hide Warranty Eligible Contractor or someone specially trained in roofing systems.

### **READ YOUR WARRANTY CAREFULLY BEFORE EXCUTING ANY ROOF-TOP WORK OR FILING OF A CLAIM.**

Understand the terms and conditions to avoid adversely affecting the warranty.

### **General Guidelines**

1. Keep the roof surface clean of debris, especially at drain areas to avoid clogging. Good roofing practice suggests that water not be allowed to remain on the roof for more than 48 hours after a rain. Keeping the roof clear of debris will allow for proper water run-off and avoid overloading the roof with standing water.
2. Keep chemical and petroleum products (acid, chemicals, solvents, greases, oils or any liquids containing petroleum products) off the membrane to avoid degradation. If swelling occurs, contact Mule-Hide immediately.
3. Do not exhaust kitchen wastes (such as but not limited to vegetable oils or animal fats) directly onto the roof surface.
4. TPO and PVC membranes may be used for restaurant roofs but must have a rooftop maintenance program in-place to ensure that accumulations of animal fats/grease are regularly removed and the membrane surface is cleaned periodically.
5. Walkways must be provided if regular rooftop traffic is required, such as routine servicing of rooftop equipment. Exercise caution when not walking on walkways, especially on white roofing surfaces as ice or frost build-up may not be visible. All membranes and coatings are slippery when wet.
6. When it is necessary for workers to be on the roof to service rooftop equipment, workers should be cautioned to use walkways (when provided) and to exercise care with their tools and equipment to avoid causing damage to the roof system that may result in leaks. It is recommended that the Building Owner or property manager keep a "Roof-top Maintenance and activity Log" to track dates and activities by personnel or other trades.
7. Handprints, footprints, general traffic grime, industrial pollutants and environmental dirt and debris may be cleaned from the roof surface by scrubbing with detergent and water, followed by rinsing with clean water. To maximize and maintain reflectivity, it is suggested that white surfaces be cleaned once every two years.
8. Keep roof maintenance items, such as counterflashings, metal curbs, metal ductwork, etc., sealed watertight at all times. All exposed mastic and sealants regardless of the purpose or function, are required maintenance items to be remediated by the Building Owner, including but not limited to pitch pans and metal flashing sealants.
9. Loss of granules from mineral surfaced membranes is typical and not a manufacturing defect. In cases of granule loss that becomes more noticeable, additional surfacing may be applied as directed by Mule-Hide.
10. Protective coating systems may oxidize and weather, losing overall dry film thickness. This is normal and not a defect in the material.
11. When performing inspections, examine all areas adjacent to the roof, parapet walls and adjoin structures. Damage to items such as masonry, failing mortar joints, loose or missing sealants, loose stone or tiles, loose or improperly sealed counterflashings, etc., may be the source of leaks that are inadvertently blamed on the roofing system. These items need to be addressed by properly trained personnel to avoid damage to the roof system.
12. If any changes are to be made to the roof system such as but not limited to equipment changes, additions or removal, modifications to the roof systems, etc., contact Mule-Hide for prior approval. Work directly related to the roof system must be completed by a Mule-Hide Warranty Eligible Contractor.
13. If you have a leak, check for the obvious such as clogged drains, broken skylights, loose counterflashings, broken pipes, leaking HVAC units or damage caused by service personnel or storms. Note: When leaking occurs, items such as heavy or light rain, wind direction and speeds, temperature and time of day are all important clues for tracking suspected leaks. Does the leak start and stop with the rain, or, does leaking continue after rain has ceased?

If you believe that the leak may be covered under a Mule-Hide warranty, please notify Mule-Hide Warranty Claims with written notice in accordance with the warranty terms. For temporary repairs, only use products that are compatible with the roof system installed. Do not use any asphalt products on any single-ply roof system as use of such product may cause additional damage to the roof system. Please refer to the Mule-Hide Website ([www.mulehide.com](http://www.mulehide.com)) for compatible products that may be used for temporary repairs on your roof system. Non-compatible products used that cause damage to the roof system will have to have that area removed and replaced at the Building Owner's expense. Compliance with the above items will aid in assuring a durable, watertight roof system.

Mule-Hide Product Co., Inc.  
P.O. Box 1057  
Beloit, WI 53512-1057  
Phone: 800-786-1492