

CUT A SECTION OF TPO NON-REINFORCED FLASHING WITH ROUNDED CORNERS OR USE UNIVERSAL CORNER; FOLD ALONG LINE AS INDICATED.

①

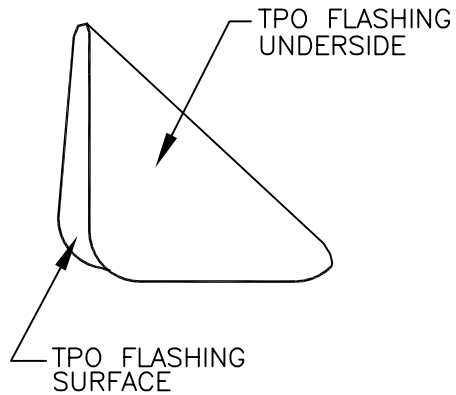

②

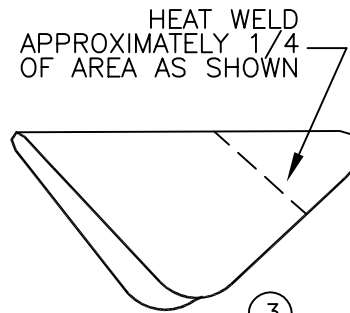

③

TRIM TRIANGULAR FLAP BEYOND EXPOSED CORNER AS SHOWN

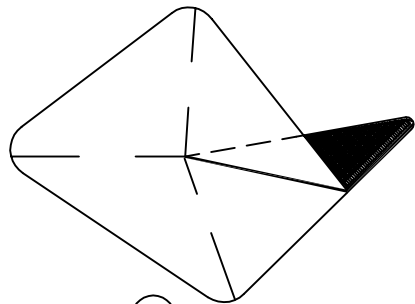

④

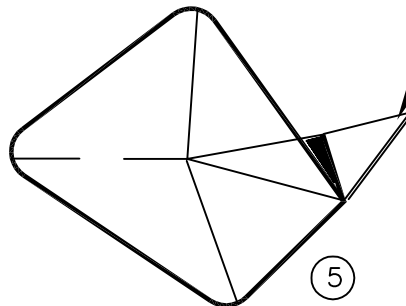

⑤

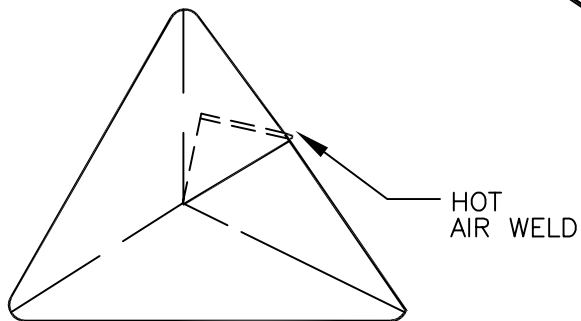

⑥ POSITION AND HEAT WELD CORNER IN PLACE AS SHOWN

TPO REINFORCED MEMBRANE
SOLID WELD FIELD FABRICATED CORNER TO COMPLETE CORNER DETAIL

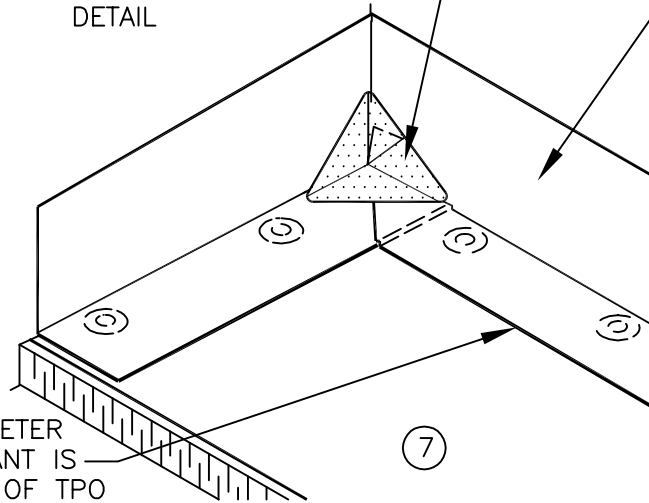

⑦

APPROXIMATELY 1/8" DIAMETER BEAD OF CUT-EDGE SEALANT IS REQUIRED ON CUT EDGES OF TPO REINFORCED MEMBRANE.

FIELD FABRICATED INSIDE CORNER

SYSTEMS:

ALL TPO SYSTEMS

DETAIL NO.:

MHT-UN-640C

REVISION DATE: 10/2013

**MULE-HIDE
PRODUCTS CO., INC.**