

NOTES:

1. ALL FLASHING MUST BE A MINIMUM OF 8" HIGH WHERE POSSIBLE
2. DO NOT COVER WEEP HOLES OR THRU-WALL COUNTERFLASHINGS
3. WHEN THE M-H ALL-PURPOSE BAR IS USED UNDER THE COUNTERFLASHING OR THE MEMBRANE IS NAILED TO THE HORIZONTAL TOP OF THE CURB, TPO BONDING ADHESIVE MAY BE ELIMINATED WHEN FLASHING HEIGHT IS 18" OR LESS.
4. APPROXIMATELY 1/8" DIAMETER BEAD OF CUT-EDGE SEALANT IS REQUIRED ON CUT EDGES OF TPO REINFORCED MEMBRANE.

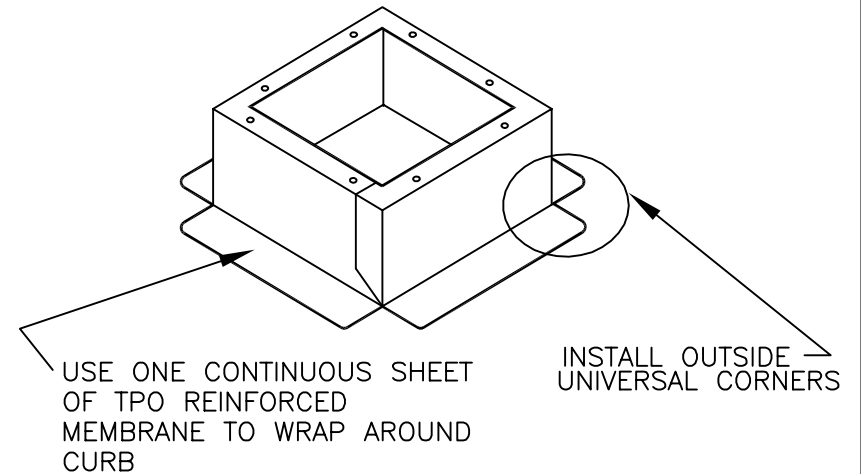

NOTE:

THIS DETAIL IS ACCEPTABLE FOR USE IN A 20-YEAR WARRANTED SYSTEM

**MULE-HIDE
PRODUCTS CO., INC.**

**CURB / WALL FLASHING
WITH M-H ALL-PURPOSE BAR
SYSTEMS:
ALL TPO SYSTEMS**

DETAIL NO.:
MHT-UN-502
REVISION DATE: 10/2013