

NON-STAINING PRESSURE SENSITIVE SEAM TAPE (TAPE PRIMER REQUIRED ON PROJECTION AND BACK OF TPO MEMBRANE)

MH HDP OR EHD FASTENER AND 2.4" SEAM PLATE, MAX 12" O.C. - SEE NOTES 2 & 3

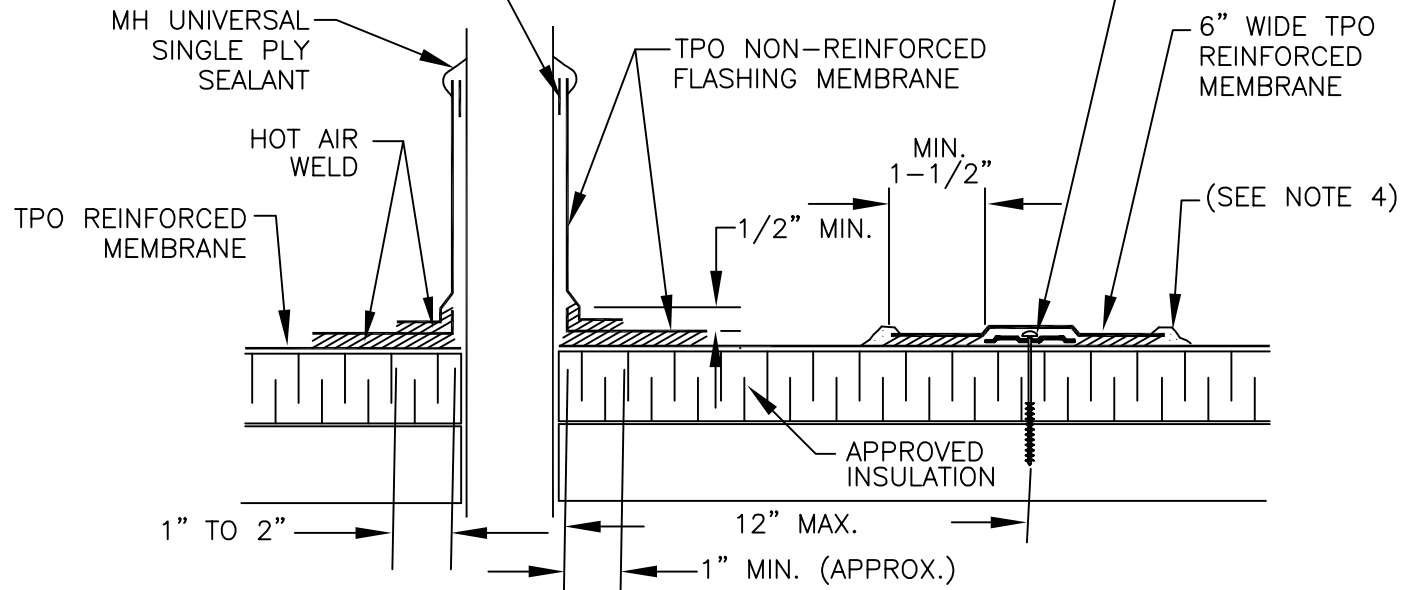

APPLY HEAT TO FLASHING AND FORM BY HAND PRIOR TO HOT AIR WELDING

NOTES:

1. REMOVE ALL LEAD AND OTHER FLASHING BEFORE INSTALLING FIELD FABRICATED PIPE SEAL.
2. ON A MECHANICALLY ATTACHED SYSTEM, INSTALL A MINIMUM OF FOUR (4) 2.4" SEAM PLATES AROUND PROJECTIONS WITH A DIMENSION UP TO 6". ADDITIONAL SEAM PLATES WILL BE REQUIRED FOR PROJECTIONS WITH DIAMETERS GREATER THAN 6" AND SHALL BE SPACED 12" ON CENTER MAX.
3. FASTENERS AND SEAM PLATES ARE NOT REQUIRED ON ADHERED SYSTEMS UNLESS PROJECTION DIAMETER EXCEEDS 18".
4. APPROXIMATELY 1/8" DIAMETER BEAD OF CUT-EDGE SEALANT IS REQUIRED ON CUT EDGES OF TPO REINFORCED MEMBRANE.
5. TEMPERATURE OF PIPE NOT TO EXCEED 160° F.

**MULE-HIDE
PRODUCTS CO., INC.**

**FIELD FABRICATED PIPE FLASHING
WITH SEAM TAPE
SYSTEMS:
ALL TPO SYSTEMS**

DETAIL NO.:
MHT-UN-521B
REVISION DATE: 10/2013