

NOTES:

1. THIS DETAIL USED FOR FIELD-FABRICATED PIPE SEAL FOR USE WITH HOT PIPE, 160° F OR HOTTER.
2. TEMPERATURE OF METAL SLEEVE MUST NOT EXCEED 160° F.
3. MUST USE EPDM TAPE PRIMER OR LOW VOC PRIMER FOR ALL EPDM MATERIALS.
4. UNIVERSAL SINGLE PLY SEALANT IS REQUIRED ON ALL EDGES OF WHITE UNCURED EPDM FLASHING TAPE.
5. EXTEND METAL SLEEVE TO ROOF DECK TO PREVENT COMBUSTIBLE MATERIALS FROM CONTACTING HOT STACK.

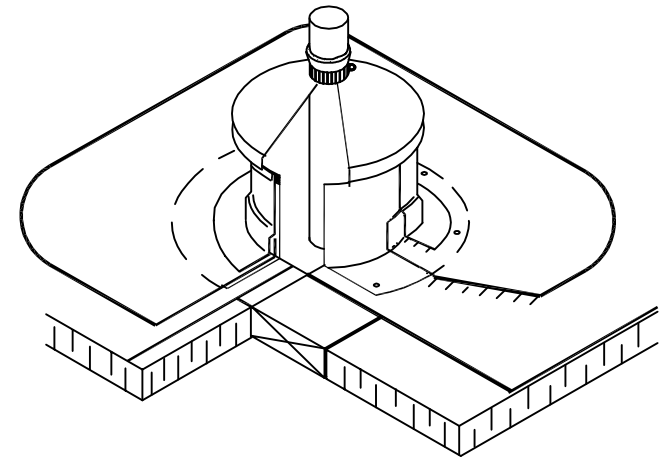

**MULE-HIDE
PRODUCTS CO., INC.**

**HOT PIPE FLASHING WITH COLD SLEEVE
WITH UNCURED EPDM
SYSTEMS:
ALL TPO SYSTEMS**

DETAIL NO.:
MHT-UN-522A
REVISION DATE: 06/2017