

NOTES:

1. DETAILS TO BE USED IN CONJUNCTION WITH STANDARD GUIDE SPECIFICATIONS CONTAINING REQUIREMENTS FOR NAILERS, INSULATION, SLIPSHEETS, ETC.
2. PVC EDGE SEALANT IS REQUIRED ON ALL CUT EDGES OR NON-ENCAPSULATED EDGES OF REINFORCED MEMBRANE. THIS INCLUDES FACTORY CUT MEMBRANE.
3. SPECIFIER/APPLICATOR MUST DETERMINE APPROPRIATE EQUIPMENT SUPPORT TO BE USED.
4. REFER TO MULE-HIDE UPLIFT RATINGS FOR APPROPRIATE FASTENER SIZE, AND SPACING.

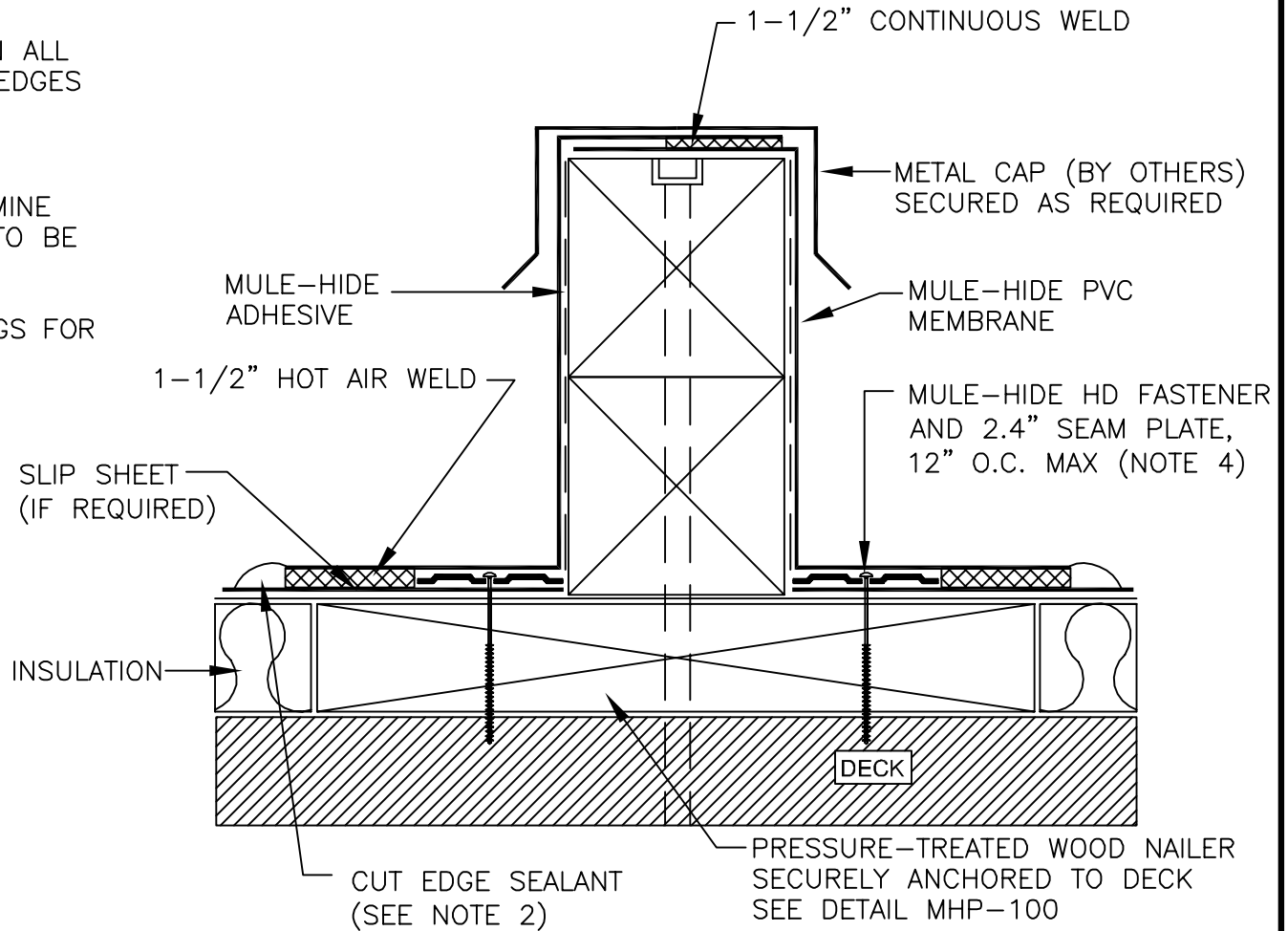

**MULE-HIDE
PRODUCTS CO., INC.
2010**

**SLEEPER SUPPORT (HEAVY WEIGHT)
SYSTEMS:
ALL PVC**

**DETAIL NO:
MHP-193**