

NOTES:

1. ALL JOINTS ARE TO BE SEALED WITH AN APPROVED SEALANT
2. SPLICE CLEATS ARE INSTALLED 24" ON CENTER USING FOUR APPROVED FASTENERS.
3. EDGES PRE-NOTCHED FOR AN OVERLAPPED JOINT.
4. COPING WIDER THAN 16" REQUIRES ADDITIONAL TOP FASTENERS.
5. INSTALL 4" WIDE SPLICE CLEATS 24" ON CENTER USING FOUR APPROVED FASTENERS (MUST POSITION A CLEAT AT EACH JOINT).
6. WHEN MORE THAN ONE ARCHED COPING CAP IS USED, INSTALL THE CAP TO SHED WATER DOWN THE ARCH BY CENTERING ONE SECTION AT THE TOP OF THE ARCH.
7. ADDITIONAL ARCHED COPING SECTIONS ARE PRE-NOTCHED TO PROVIDE AN OVERLAPPED JOINT. APPLY AN APPROVED SEALANT AT ALL COPING JOINTS.
8. COPING 16" TO 24" WIDE WILL REQUIRE A ROW OF HEX-HEAD SCREWS WITH NEOPRENE WASHERS IN THE CENTER.
9. COPING 25" OR WIDER SHALL REQUIRE TWO ROWS OF HEX-HEAD SCREWS WITH NEOPRENE WASHERS. ALL FASTENERS SHALL BE INSTALLED AT 18" ON CENTER ALONG THE LENGTH OF THE COPING.
10. MUST USE STAINLESS STEEL FASTENERS IF FASTENING INTO ACQ TREATED WOOD

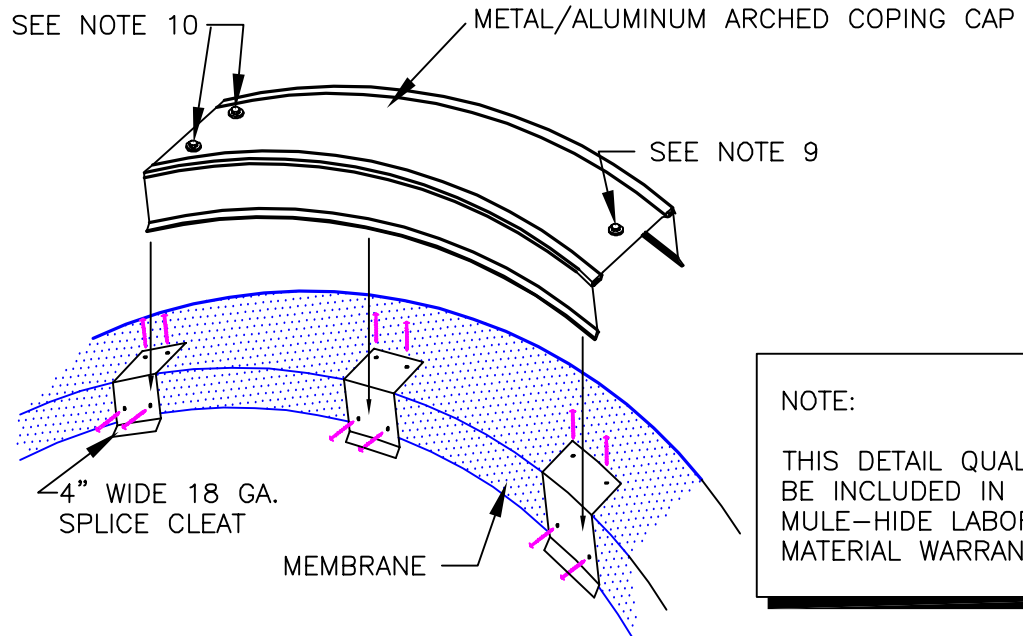
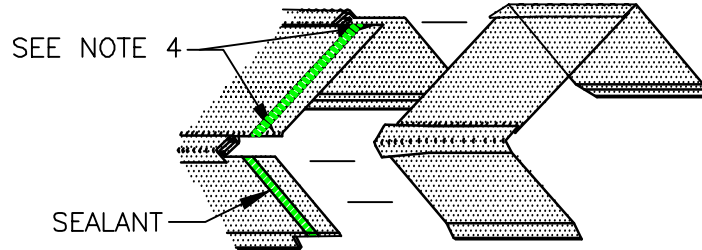
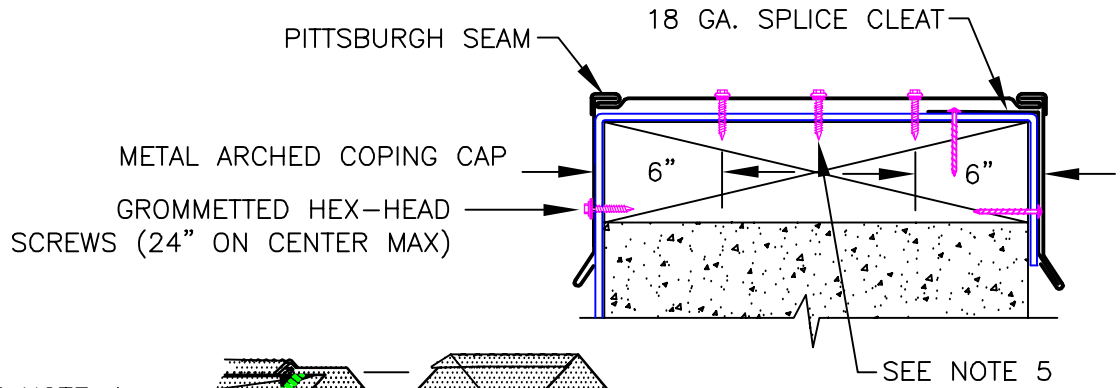

NOTE:  
THIS DETAIL QUALIFIES TO BE INCLUDED IN ANY MULE-HIDE LABOR AND MATERIAL WARRANTY

**MULE-HIDE  
PRODUCTS CO., INC.**

**MULE-HIDE PREMANUFACTURED  
ARCHED COPING W/SPLICE PLATE  
SYSTEMS:**

**ALL MULE-HIDE SYSTEMS**

**DETAIL NO.:**

**MHSM-6056**

REVISION DATE: 01/2013