

NOTES:

1. SNAP CLEATS AT CORNER – PLACE SNAP CLEATS 12” FROM THE CORNER OF THE BUILDING. PULL EACH CLEAT SNUGLY AGAINST THE FACE OF THE BUILDING. INSTALL FOUR GROMMETTED HEX HEAD SCREWS.
2. CORNER SUPPORT CLIPS – CORNER SUPPORT CLIPS ARE TO BE PLACED AT ALL OUTSIDE CORNERS TO SUPPORT THE CAP. SET THE CLIP AWAY FROM THE CORNER ABOUT ½’. JOINTS MUST BE 12” OR MORE FROM CORNER.
3. SNAP CLEATS AT WALL ENDS – INSTALL THE FIRST SNAP CLEAT APPROXIMATELY 2” FROM THE WALL END.
4. SNAP CLEATS ALONG THE PARAPET – INSTALL SNAP CLEATS ALONG THE LENGTH OF THE PARAPET ON 60” CENTERS. COPING PIECES LONGER THAN 5’ MUST HAVE THREE CLEATS: ONE AT EACH END AND ONE IN THE CENTER. MAXIMUM CLEAT SPACING IS 60” ON-CENTER.
5. INSTALLING COPING CORNER – PLACE THE CONCEALED JOINT SPLICE OVER THE ANCHOR CLEAT AT EACH CLEAT LOCATION. HOOK THE FACE OF THE CORNER OVER THE OUTSIDE FACE LEG OF THE CLEAT, ROTATE THE CAP OVER THE TOP OF THE CLEATS, AND SNAP THE ROOF SIDE LEG BY PRESSING DOWN ON THE COPING BACK LEG. JOINTS MUST BE 12” OR MORE FROM EACH CORNER.
6. BEGIN INSTALLING STRAIGHT LENGTHS OF COPING FROM THE ENDS, WORKING INWARD TO THE CENTER, AND LEAVING A ¼” GAP BETWEEN THE COPING SECTIONS FOR THERMAL EXPANSION. THERE SHOULD BE A CLEAT AT EACH JOINT AND AT LEAST ONE CLEAT IN THE MIDDLE OF EACH SECTION LONGER THAN 5’.

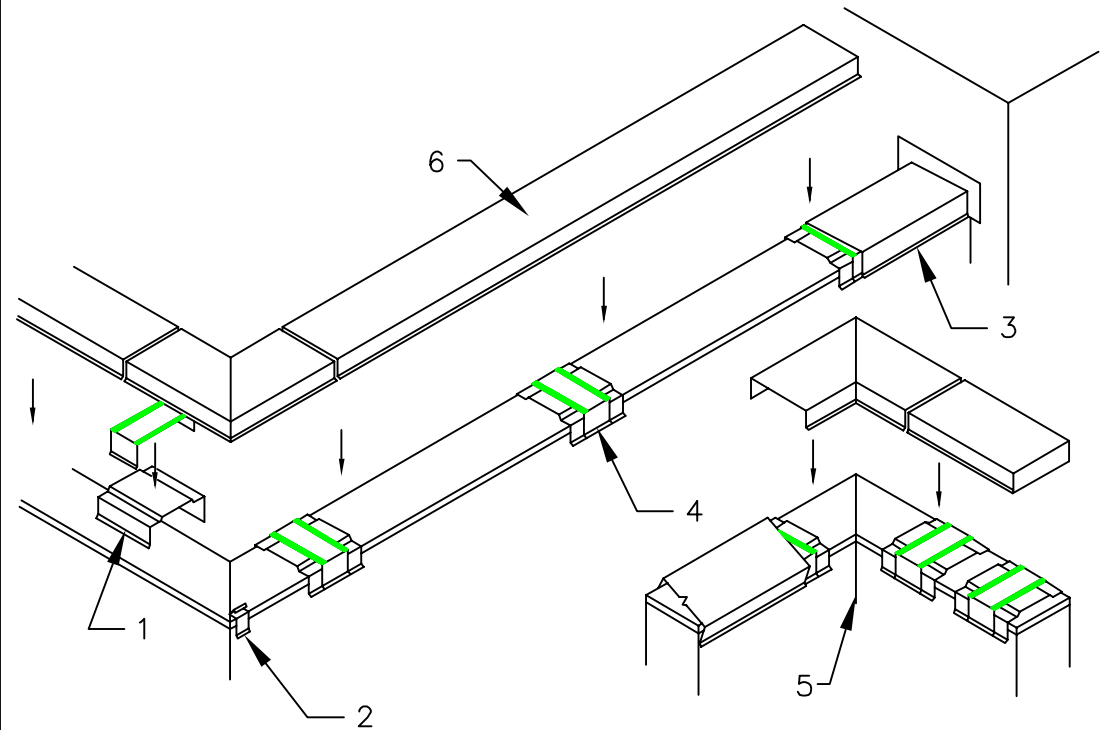

NOTE:

THIS DETAIL QUALIFIES TO BE INCLUDED IN ANY MULE-HIDE LABOR AND MATERIAL WARRANTY

**MULE-HIDE  
PRODUCTS CO., INC.**

**MULE-HIDE PREMANUFACTURED  
SNAP COPING  
SYSTEMS:**

**ALL MULE-HIDE SYSTEMS**

**DETAIL NO.:**

**MHSM-6054B**

REVISION DATE: 01/2013